

Table of Contents

CHAPTER 5: GEOMETRIC FIGURES AND SCALE DRAWINGS (3-4 WEEKS)	2
5.0a Chapter Project: Constructing Scale Drawings 1	5
5.0a Chapter Project: Constructing Scale Drawings 2	7
5.0b Review: Angle Classification and Using a Protractor.....	8
SECTION 5.1 CONSTRUCTING TRIANGLES FROM GIVEN CONDITIONS	9
5.1a Class Activity: Triangles and Labels—What’s Possible and Why?	10
5.1a Homework: Triangle Practice.....	17
5.1b Class Activity: Building Triangles Given Three Measurements.....	20
5.1b Homework: Building Triangles Given Three Measurements	23
5.1c Class Activity: Sum of the Angles of a Triangle Exploration and 5.1 Review.....	26
5.1c Honors Extension: Sum of the Angles of a Polygon Exploration.....	27
5.1c Homework: Sum of the Angles of a Triangle Exploration and 5.1 Review.....	30
5.1d Self-Assessment: Section 5.1.....	31
SECTION 5.2: SCALE DRAWINGS.....	33
5.2a Classwork: Comparing the Perimeter and Area of Rectangles.....	34
5.2a Homework: Comparing the Perimeter and Area of Rectangles	37
5.2b Classwork: Scaling Triangles.....	38
5.2b Homework: Scaling Triangles.....	44
5.2c Class Activity: Solve Scale Drawing Problems, Create a Scale Drawing	46
5.2c Homework: Solve Scale Drawing Problems, Create a Scale Drawing.....	51
5.2d Extension Class Activity and Homework: Scale Factors and Area	53
5.2d Homework: Scale Factors and Area	55
5.2e Self-Assessment: Section 5.2	57
SECTION 5.3: SOLVING PROBLEMS WITH CIRCLES	60
5.3a Class Activity: How Many Diameters Does it Take to Wrap Around a Circle?.....	61
5.3a Homework: How Many Diameters Does it Take to Wrap Around a Circle?	65
5.3b Classwork: Area of a Circle.....	69
5.3b Homework: Area of a Circle	76
5.3c Self-Assessment: Section 5.3	79
SECTION 5.4: ANGLE RELATIONSHIPS	81
5.4a Classwork: Special Angle Relationships.....	82
5.4a Homework: Special Angle Relationships.....	88
5.4b Classwork: Circles, Angles, and Scaling.....	92
5.4b Homework: Review Assignment.....	95
5.4c Self-Assessment: Section 5.4	100

Chapter 5: Geometric Figures and Scale Drawings (3-4 weeks)

UTAH CORE Standard(s)

Draw construct, and describe geometrical figures and describe the relationships between them.

1. Solve problems involving scale drawings of geometric figures, including computing actual lengths and areas from a scale drawing and reproducing a scale drawing at a different scale. 7.G.1
2. Draw (freehand, with ruler and protractor, and with technology) geometric shapes with given conditions. Focus on constructing triangles from three measures of angles or sides, noticing when the conditions determine a unique triangle, more than one triangle, or no triangle. 7.G.2

Solve real-life and mathematical problems involving angle measure, area, surface area, and volume.

4. Know the formulas for the area and circumference of a circle and use them to solve problems; give an informal derivation of the relationship between the circumference and area of a circle. 7.G.4
5. Use facts about supplementary, complementary, vertical, and adjacent angles in a multi-step problem to write and solve simple equations for an unknown angle in a figure. 7.G.5
6. Solve real-world and mathematical problems involving area, volume and surface area of two- and three-dimensional objects composed of triangles, quadrilaterals, polygons, cubes, and right prisms. 7.G.6

CHAPTER 5 OVERVIEW:

Chapter 5 builds on proportional relationships studied in chapter 4 and extends those ideas to scaling and the affects of scaling. The chapter starts by expiring conditions under which one can construct triangles and when conditions establish unique triangles. From there, students move in section 2 to scaling objects and exploring how scaling a side of an object affects the perimeter and area measures. Section 3 helps students understand that all circles are scaled versions of one another and how that fact allows us to connect the diameter of a circle to its circumference and area. Finally in section 4 students use angle relationships to find missing angles.







VOCABULARY: acute triangle, angle, congruent, corresponding parts, equilateral triangle, included angle, included side, isosceles triangle, obtuse triangle, right triangle, scalene triangle, triangle inequality theorem.

CONNECTIONS TO CONTENT:

Prior Knowledge: In elementary school students found the area of rectangles and triangles. They measured and classified angles and drew angles with a given measure. Though students learned about circles informally, haven't learned how to find circumference and area.

Future Knowledge: The term “similarity” is formally defined in the 8th grade. In 7th grade we will say “same shape”. In 8th grade students will justify that the angles in a triangle add to 180° and will extend that knowledge to exterior angles and interior angles of other polygons. In 8th grade students will extend their understanding of circles to surface area and volumes of 3-D figures with circular faces. In 9th grade students will formalize the triangle congruence theorems (SSS, SAS, AAS, ASA) and use them to prove facts about other polygons. In 8th grade students will expand upon “same shape” (scaling) and extend that idea to dilation of right triangles and then to the slopes of lines. In 10th grade students will formalize dilation with a given scale factor from a given point as a non-rigid transformation (this will be when the term “similarity” will be defined) and will solve problems with similar figures. The understanding of how the parts of triangles come together to form its shape will be deepened in 8th grade when they learn the Pythagorean Theorem, and in 11th grade when they learn the Law of Sines and Law of Cosines.

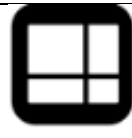
MATHEMATICAL PRACTICE STANDARDS (emphasized):

	Make sense of problems and persevere in solving them.	Students will analyze pairs of images to determine if they are exactly the same, entirely different or if they are the same shape but different sizes. With this information they will persevere in solving problems.
	Reason abstractly and quantitatively.	Students will find scale factors between objects and use them to find missing sides. They will also note that proportionality exists between two sides of the same object. Students should move fluidly from $a:b = c:d \rightarrow a:c = b:d$, etc. and understand why all these proportions are equivalent. Further, students should fluidly transition between proportionality and scale factor. E.G. If $\triangle ABC: \triangle DEF$ is 2:3 then the scale factor that takes $\triangle ABC$ to $\triangle DEF$ is $3/2$.
	Construct viable arguments and critique the reasoning of others.	Students should be able to construct a viable argument for why two objects are scale versions of each other AND how to construct scale versions of a given object. Further, students should be able to explain why, for example, if the scale between two objects is 5:3 then a length of 20 on the first object becomes 12 on the new object by using pictures, words and abstract representations.
	Model with mathematics.	Students should be able to create a model (table of values, bar model, number line, etc.) to justify finding proportional values. Additionally, students should be able to start with a model for a proportional relationship and then write and solve a mathematical statement to find missing values.
	Attend to precision	Students should attend to units throughout. For example, if a scale drawing is 1mm = 3 miles, students should attend to units when converting from 4mm to 12 miles. Students should also carefully attend to parallel relationships: for example for two triangles with the smaller triangle having sides a, b, c and a larger triangle that is the same shape but different size with corresponding sides d, e, f , the proportion $a:d = b:e$ is equivalent to $a:b = d:e$ but sets up relationships in a different manner.
	Look for and make use of structure	Students will link concepts of concrete representations of proportionality (bar models, graphs, table of values, etc.) to abstract representations. For example, if a length 20 is to be scaled down by a factor of 5:3 one can think of it as something times $(5/3)$ is 20 OR 20 divided by 5 taken 3 times.
	Use appropriate tools strategically.	By this point, students should set up proportions using numeric expressions and equations, though some may still prefer to use bar models. Calculators may be used as a tool to divide or multiply, but students should be encouraged to use mental math strategies wherever possible. Scaling with graph paper is also a good tool at this stage.
	Look for and express regularity in repeated reasoning	Students should connect scale to repeated reasoning. For example if the scale is 1:3 then each length of the shorter object will be multiplied by 3 to find the length of the larger scaled object; then to reverse the process, one would divide by three.



from: <http://disneyscreencaps.com/wreck-it-ralph-2012/5/#/>

Cartoon characters are supposed to be illustrated versions of human beings. In a way, we could think about a cartoon character as a scale drawing of a human.

What if Wreck-it Ralph was a scale drawing of you!? If you were Wreck-it Ralph but still at your current height, how tall would your head be?

How big would your hands be?

Students will set up proportions

How long would your legs be?

Wreck-it Ralph to Student

$$\frac{\text{Wreck-it Ralph Head height}}{\text{Body height}} = \frac{\text{Student Head height}}{\text{Body height}}$$

5.0a Chapter Project: Constructing Scale Drawings 1

Task: Making a scale drawing of the top of your desk

- Use measuring tools and scissors to cut a piece of letter-sized plain paper or graph paper to be a scale model of the top of your desk.
- Write the scale on the corner of the paper.
- Place *at least* 3 items on your desk. For example, a pencil, eraser, book, soda can, cell phone, etc.
- Fill in the table of values below with measurements or calculations. You can choose what to measure for the five blank rows. The blanks in the column headings are to write what units you measured in (cm, inches, mm, units of graph paper, etc.)

Item measured	Real measurement is _____	Measurement in scale drawing is _____
A) Short side of top of desk		
B) Long side of top of desk		
C)		
D)		
E)		
F)		
G)		

- Use measuring tools to draw your three items, to scale and in the same position as they are on your desk, on your scale drawing.
- Graph the information from your table on the grid on the next page, labeling each point with the letter A-G from the row of the table. Be sure to label the axes.

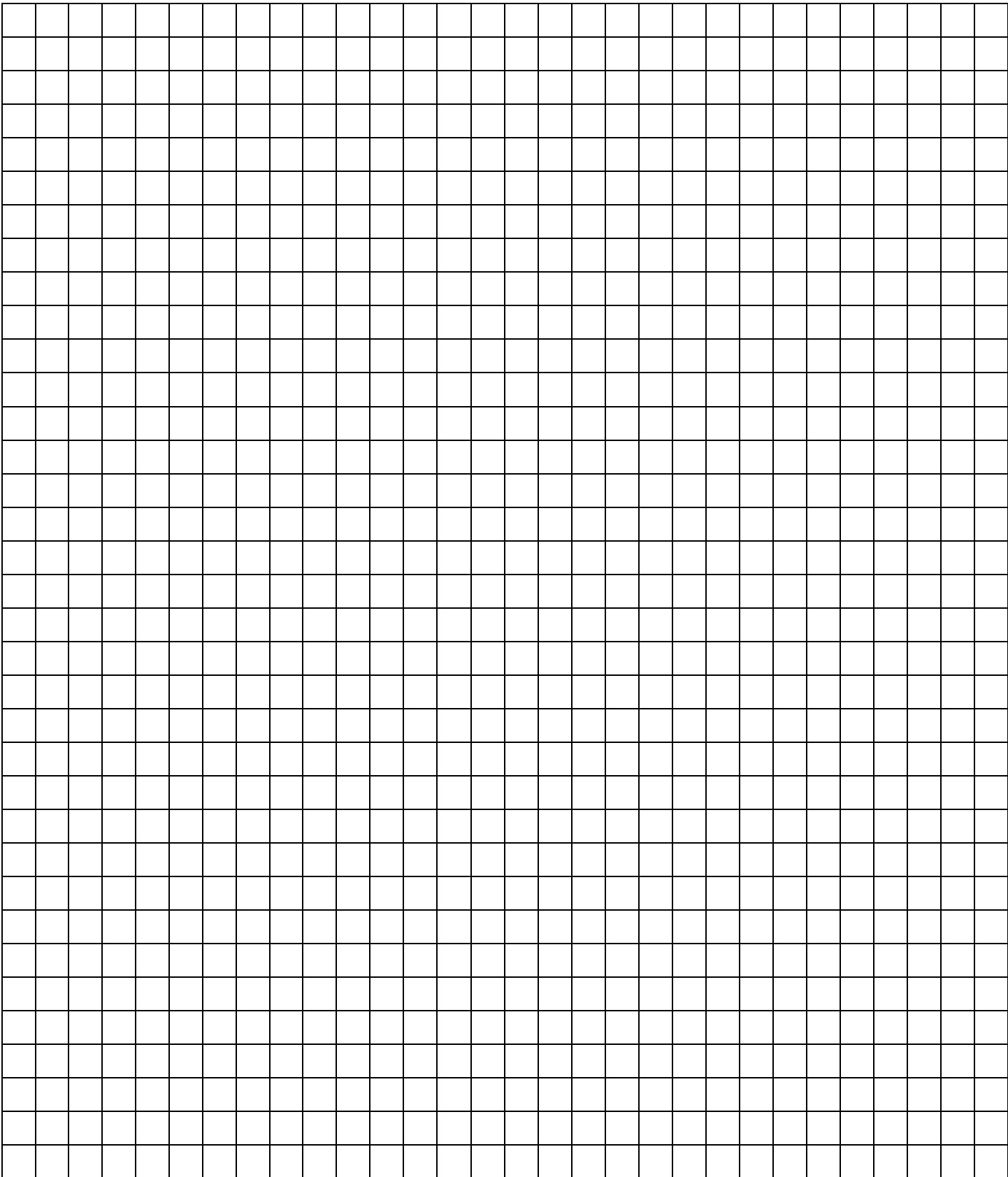

5.0a Chapter Project: Constructing Scale Drawings 2

Task: Making a scale drawing as a class. Choose *one* of the images below and make a scale drawing.





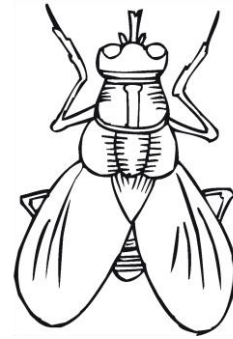
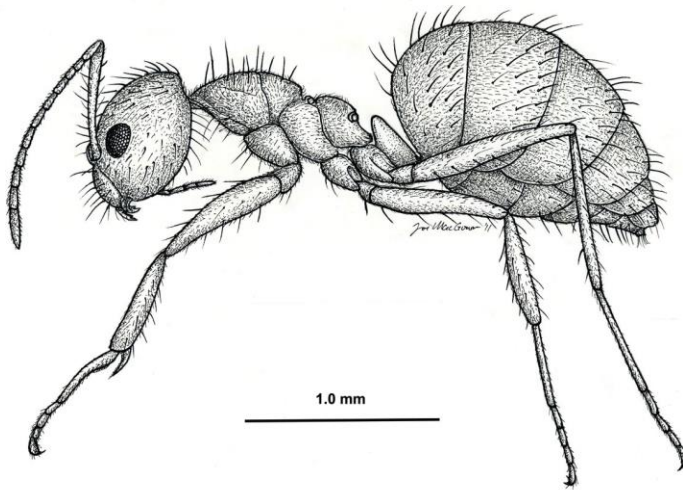



Below is an image of an ant (Nylanderia Pubens Worker ant) and a common house fly (Diptera).

- Use measuring tools to make a scale drawing of either the ant or fly picture below.
- Determine your scale.

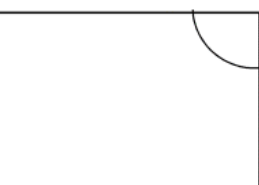

5.0b Review: Angle Classification and Using a Protractor

Review Angles: For each angle below, a) use a protractor to find the measurement in degrees and b) write its classification (acute, obtuse, right or straight.)

Angle	Degrees	Classification	Angle	Degrees	Classification
1. 	_____	<u>right</u>	2. 	_____	<u>acute</u>
3. 	_____	<u>obtuse</u>	4. 	_____	
5. 	_____	<u>right</u>	6. 	_____	
7. 	_____	<u>straight</u>	8. 	_____	

Section 5.1 Constructing Triangles from Given Conditions

Section Overview:

In this section, students discover the conditions that must be met to construct a triangle. Reflecting the core, the approach is inductive. By constructing triangles students will note that the sum of the two shorter lengths of a triangle must always be greater than the longest side of the triangle and that the sum of the angles of a triangle is always 180 degrees (*see the mathematical foundation for a discussion of these ideas.*) They then explore the conditions for creating a unique triangle: three side lengths, two sides lengths and the included angle, and two angles and a side length—whether or not the side is included. This approach of explore, draw conclusions, and then seek the logical structure of those conclusions is integral to the new core. It is also the way science is done. In later grades students will more formally understand concepts developed here.

In 7th grade, students are to learn about “scaling.” The concepts in this section are foundational to scaling and then lead to proportional relations of objects that have the same “shape” in section 5.2. In 8th grade, students will extend the idea of scaling to dilation and then in Secondary I to similarity. The word “similar” may naturally come up in these discussions; however, it is best to stay with an intuitive understanding. A definition based on dilations will be floated in eighth grade, but will not be fully studied and exploited until 10th grade. In this section emphasis should be made on conditions necessary to create triangles and that conditions are related to knowing sides and angles.

Concepts and Skills to be Mastered (from standards)

Geometry Standard 2: Draw (freehand, with ruler and protractor, and with technology) geometric shapes with given conditions. Focus on constructing triangles from three measures of angles or sides, noticing when the conditions determine a unique triangle, more than one triangle, or no triangle. 7.G.2

Geometry Standard 6: Solve real-world and mathematical problems involving area, volume and surface area of two- and three-dimensional objects composed of triangles, quadrilaterals, polygons, cubes, and right prisms. 7.G.6

1. Given specific criteria, construct a triangle and know if it's a unique triangle
2. Understand and explain the side length requirements of a triangle.
3. Understand and explain the angle and side requirements for constructing a unique triangle.
4. Know the angle measure requirements of a triangle. (Triangle Angle Sum Theorem)

5.1a Class Activity: Triangles and Labels—What’s Possible and Why?

Review Triangle: Write a description and sketch at least one example for the following terms: In elementary school, students learned these terms. Remind students that triangles are classified by **angle measure** and/or **side length**. Also, recall that all equilateral triangles are isosceles.

- a. Acute triangle:
All acute angles.

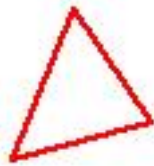

- b. Obtuse triangle:
One obtuse angle



- c. Right triangle:
One right angle



- d. Equilateral triangle:
All sides the same length

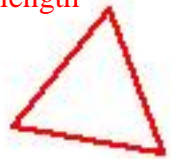

- e. Isosceles triangle:
At least two sides are the same length



- f. Scalene triangle:
Each side a different length

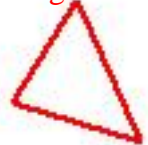

Activity: The Engineer’s Triangle: How many different triangles can an engineer make out of an 18 unit beam?

You’re an engineer and you need to build triangles out of 18 foot beams. How many different triangles can you make with an 18 foot beam? What do you notice about the sides of different triangles? What do you notice about the angles of different triangles?

In groups of 2-4, cut out several “18 foot beams.” Your group’s task is to make different triangles with your “beams.” For each triangle you construct, use the table below to classify it by angles and sides.

Be careful to line up the **exact corners** of the strips, like this:

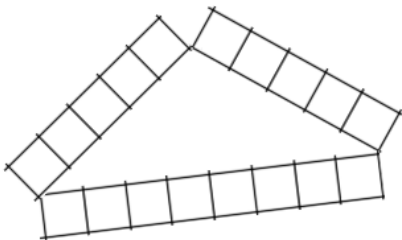

NOT at the center, like this:

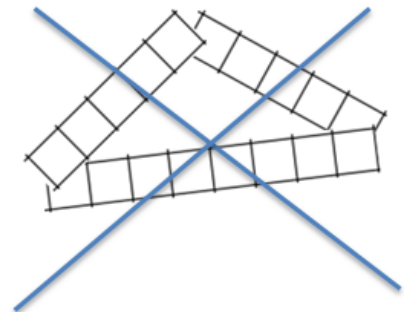

GROUP RECORDING SHEET

For each triangle you construct: 1) record the length of each side, 2) the measure of each angle, 3) classify by angle and 4) classify by side. Pay attention to patterns. If you discover a pattern, write it down your conjecture.

The lengths of each side. Be sure to state units.	The measure of each angle, to the nearest 5° .	Classify each triangle by side: Scalene, Isosceles, or Equilateral	Classify each triangle by angle: Right, Acute, or Obtuse
A.			
B.			
C.			
D.			
E.			
F.			
G.			
H.			
I.			
J.			
K.			

Write the three numbers for the lengths of the side dimensions.	Write the three numbers for the angle measures, to the nearest 5°.	Write whether the triangle was Right, Acute, or Obtuse	Write whether the triangle was Scalene, Isosceles, or Equilateral
L.			
M.			
N.			
O.			
P.			
Q.			
R.			
S.			
T.			
U.			

Instructions: Cut along the dotted lines to get strips 18 units long. Each unit represents one foot. For each trial, one member of your group will cut the strip into three pieces for the three side lengths of a possible triangle. Tape the triangle down when you've constructed it to help make the angle measuring easier.

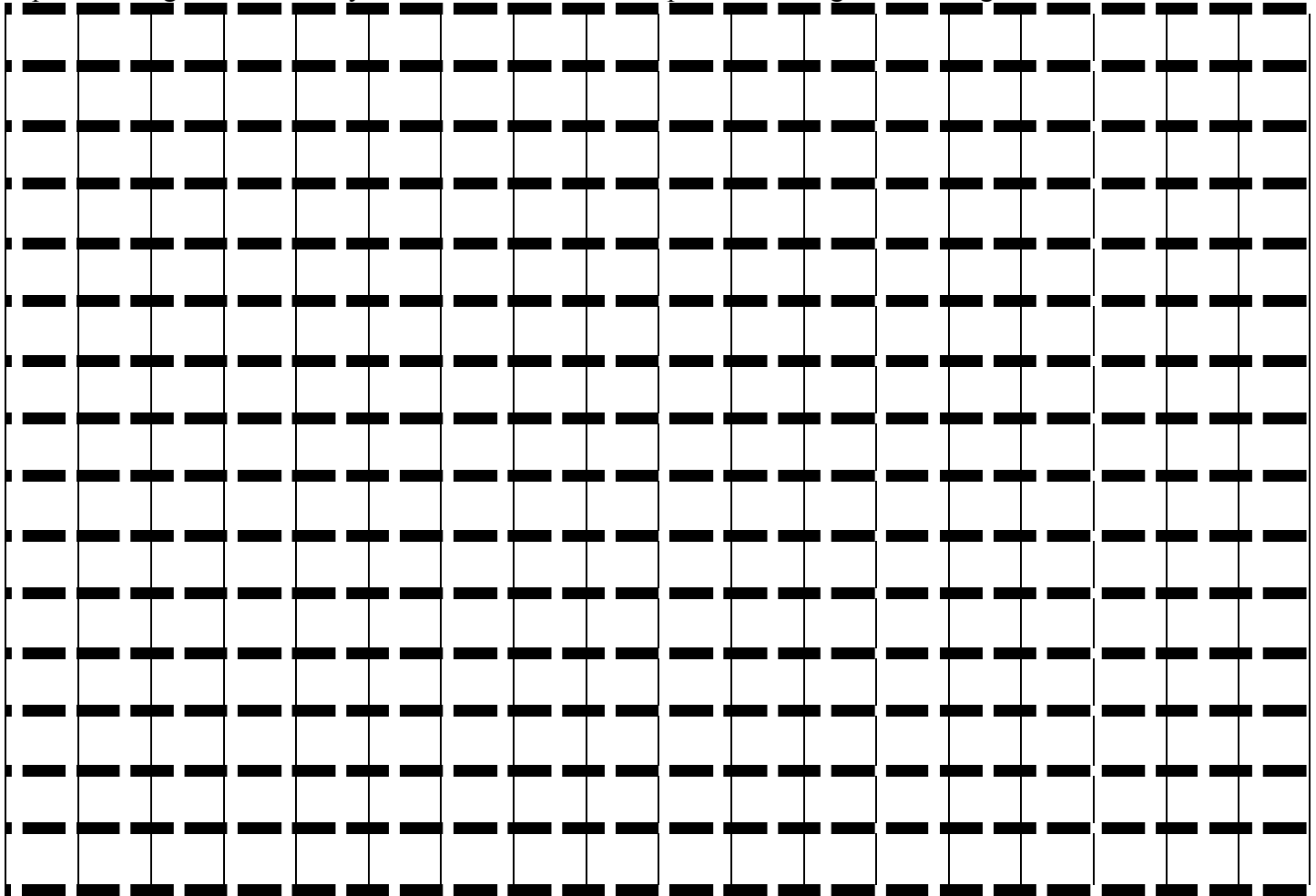

Review: Using a protractor to find the measure of the angle.

Use the *inside* row, since this an obtuse angle. Thus, the angle is 100° , not 80° .

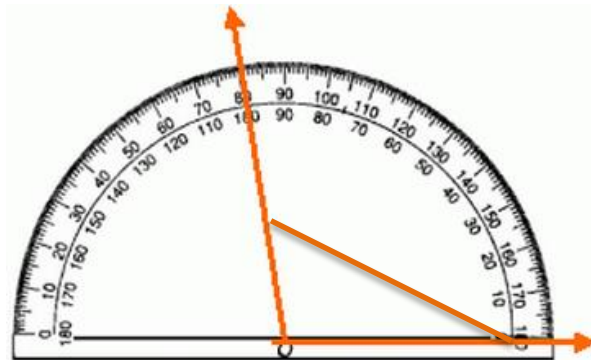

- Is there more than one way to put together a triangle with three specific lengths?
No. Help students see that 3 known sides always create a unique triangle (when a triangle is actually created). This is the first time the word “unique” will likely come up. You should take time to explore the triangle. Note that regardless of the triangle’s orientation, the same triangle is always created. In 8th grade this will be explored further.

- What pattern do you see involving the sides of the triangle? **The sum of the two shorter sides of the triangle must be greater than the longest side in order for a triangle of area greater than 0 to be formed.**



Encourage students to support their conjectures. Push students to reason why the sum of the two shorter sides cannot equal the longer side. **READ THE MATHEMATICAL FOUNDATION FOR FURTHER DISCUSSION OF THIS POINT.** We’ve merely observed through experimentation that it’s true. To “prove” it’s true, we need to construct a sound argument. Note that when students study trig ratios, they will work with triangles where the sum of the two shorter sides is equal to that of the longest (hypotenuse) e.g. $\sin 0 = 0$.

- What pattern do you see involving the angles of the triangle? **The sum of the angles of a triangle equal 180°.**

- For each group of three side lengths in inches, determine whether a triangle is possible. Write yes or no, and justify your answer.

a. $14, 15\frac{1}{2}, 2$ **Yes**

b. $1, 1, 1$ **Yes, is equilateral**

c. $7, 7, 17$ **No, the sum of the two shorter sides is not as long as 3rd side.**

d. $3, 9, 4$ **No, the sum of the two shorter sides is not as long as 3rd side.**

e. $6\frac{1}{3}, 5, 4$ **Yes**

f. $3, 2, 1$ **No**

- If two side lengths of a triangle are 5 cm and 7 cm, what is the smallest possible *integer* length of the third side? **3 cm.** If we did not restrict to integers, anything larger than 2 cm would work. Explore this idea with students. Would 2.5cm, 2.1cm, 2.01cm work? etc....



Students are using repeated reasoning to answer questions.

- If two side lengths of a triangle are 5 cm and 7 cm, what is the largest possible *integer* length of the third side? **11 cm**—note that at 12 the other two sides would fall flat so the largest **INTEGER** value is 11. Again, take time to explore 11.5, 11.9, 11.99, etc.

If students do not have access to a protractor at home, you may copy these images of protractors on a transparency, cut them out, and give to students.

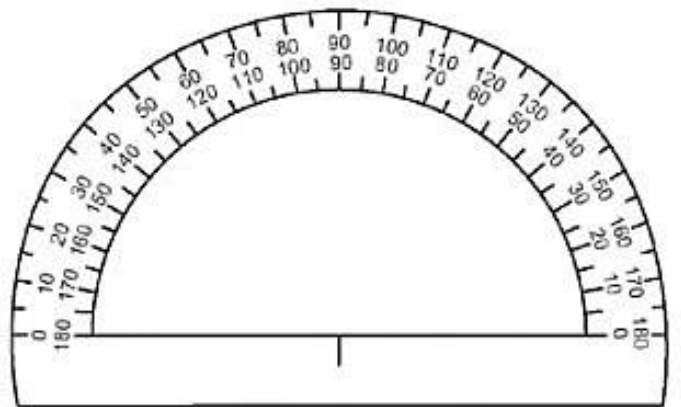
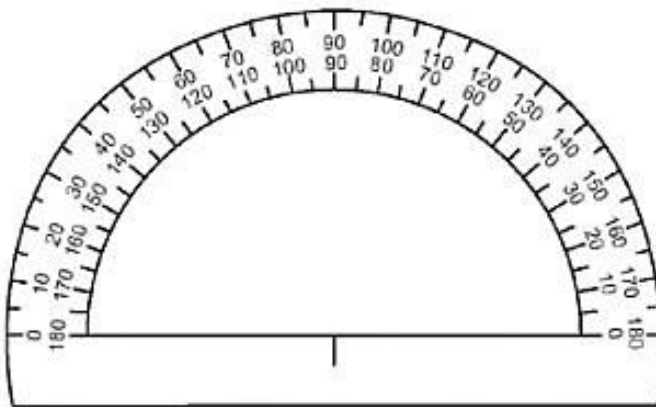
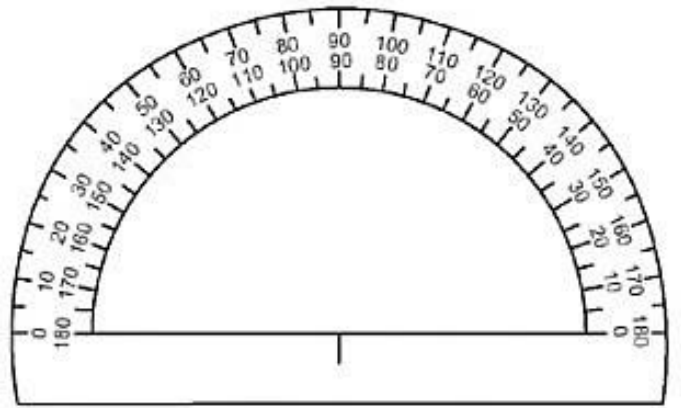
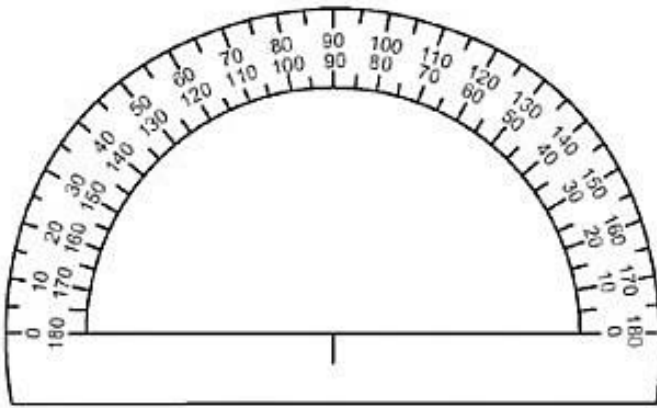
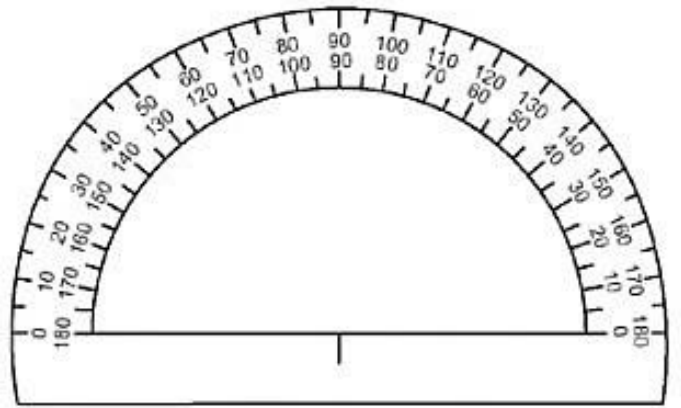
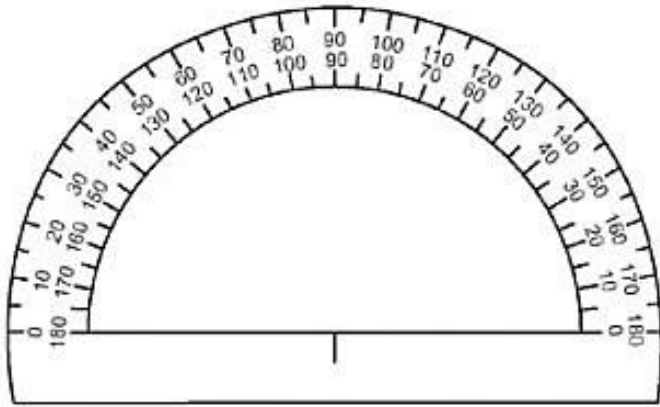

Spiral Review

1. Simplify $-27.3 + 6.2 = -21.1$

2. Find 45% of 320 without a calculator 144

32	32	32	32	32	32	32	32	32	32
----	----	----	----	----	----	----	----	----	----



10% is 32, you need 4.5 of them

3. Evaluate $-3x + 1.4$ for $x = -3$ -7.6

4. Kim, Laurel, and Maddy are playing golf. Kim ends with a score of -8 . Laurel's score is -4 . Maddy scores $+5$. What is the difference between the scores of Maddy and Kim? $5 - -8 =$

13 , Maddy had 13 more strokes than Kim

5. The temperature increased 2° per hour for seven hours. How many degrees did the temperature raise after seven hours? $7 \times 2 = 14$ so 14 degrees.

5.1a Homework: Triangle Practice

1. Explain what you know about the lengths of the sides of a triangle (the triangle inequality theorem.) **The sum of the two shorter sides of a triangle must be greater than the length of the longest side.**

For #2-7, (a) Carefully copy the triangle using a ruler and protractor, technology, or other means. Label the side lengths and angle measures for your new triangle. For side length units, use either centimeters or inches. (b) Write an inequality that shows that the triangle inequality holds. (b) Classify the triangle as equilateral, isosceles, or scalene by examining the side lengths. (d) Classify the triangle as right, obtuse, or acute by examining the angle measures.

2.

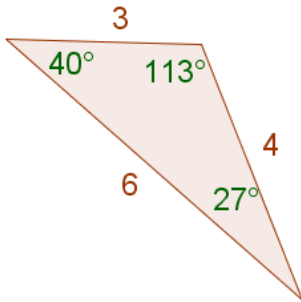

3.

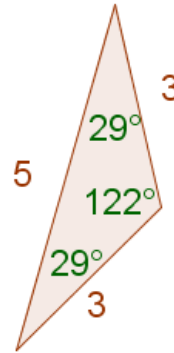

$$6 < 4 + 3 \text{ or } 4 < 6 + 3 \text{ or } 3 < 6 + 4$$

Scalene

Obtuse

4.

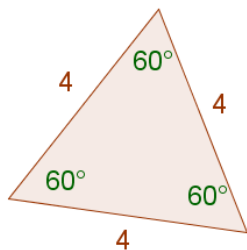

5.

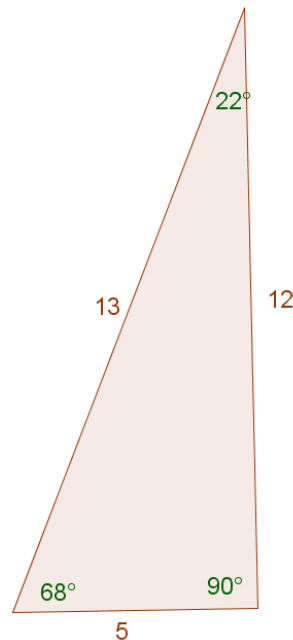

6.

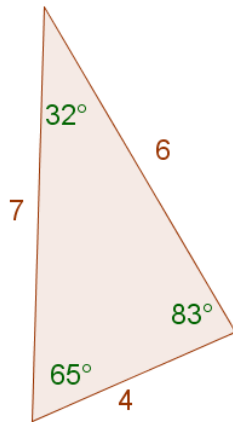

7.

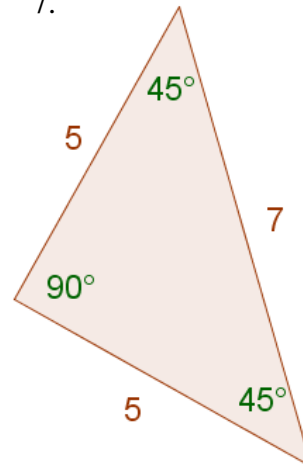

$$7 < 5 + 5$$

$$5 < 7 + 5$$

Isosceles

Right

True or false. Explain your reasoning—if false, give a counter example.

8. An acute triangle has three sides that are all different lengths.

False, look for a counter example such as an equilateral triangle.

9. A scalene triangle can be an acute triangle as well.

10. An isosceles triangle can also be a right triangle.

True - see #7 above.

11. If two angles in a triangle are 40° and 35°, the triangle must be acute.

12. An obtuse triangle can have multiple obtuse angles.

13. A scalene triangle has three angles less than 90 degrees.

False, a triangle can be obtuse and scalene at the same time – see #2 above.

14. A triangle with a 100° angle must be an obtuse triangle.

15. The angles of an equilateral triangle are also equal in measure.

16. Write whether the three given side lengths can form a triangle. If not, draw a sketch showing why it doesn't work.

a. 8, 1, 8

Yes

c. 1, 4, 10

No

e. 15, 8, 9

g. 4, 3, 6.9

b. 3, 3, 3

d. $1\frac{1}{2}, 5, 3\frac{1}{2}$

f. 2, 2, 15

h. $\frac{1}{3}, \frac{1}{3}, \frac{1}{3}$

Yes

17. Anna used the scale on a map to calculate the distances “as the crow flies” (meaning the perfectly straight distance) from three points in Central America and the Caribbean islands, marked on the map to the right.

a. According to Anna, how far is it from Jamaica to Panama if you don't go through Honduras?

700 miles

b. According to Anna, how far is it from Jamaica to Panama if you do go through Honduras?

600 miles

c. Another way of stating the triangle inequality theorem is “the shortest distance between two points is a straight line.” Explain why Anna must have made a mistake in her calculations. **Her calculations show that the shorter distance is not the straight line.**



5.1b Class Activity: Building Triangles Given Three Measurements

Preparation for task: included angles.

1. Circle all the triangles with side lengths 8 and 5 and an *included angle* of 32° .

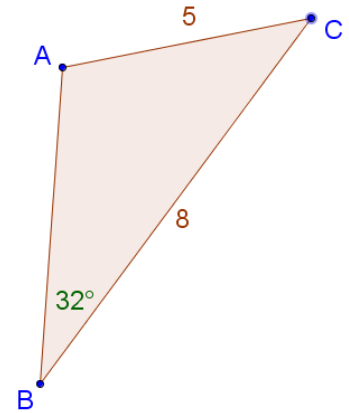
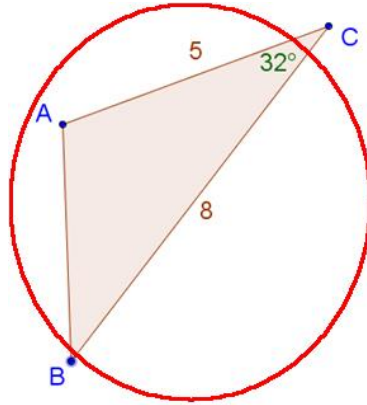
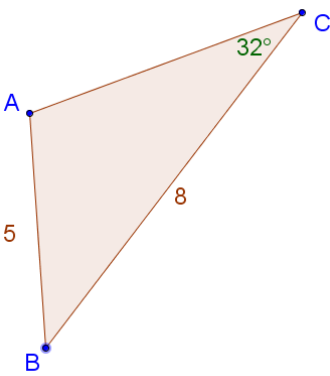

2. Circle all the triangles with side lengths 4 and 3, with a *non-included angle* of 50° adjacent to the side with length 3.

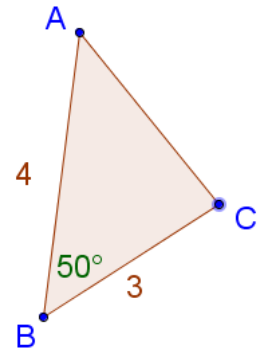
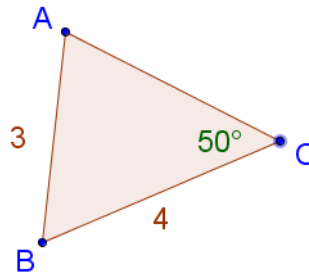
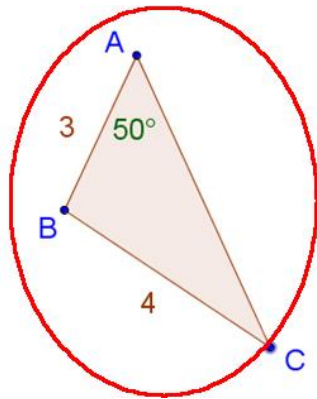
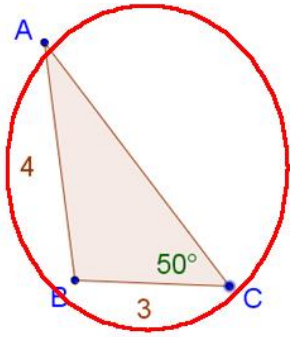

3. Circle all the triangles with two angles 90° and 28° with an *included side* of 6 units.

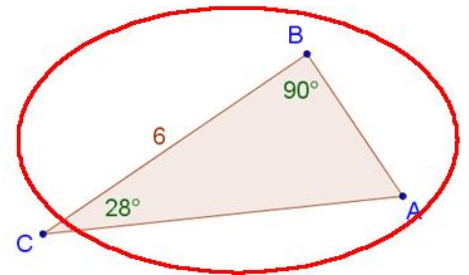
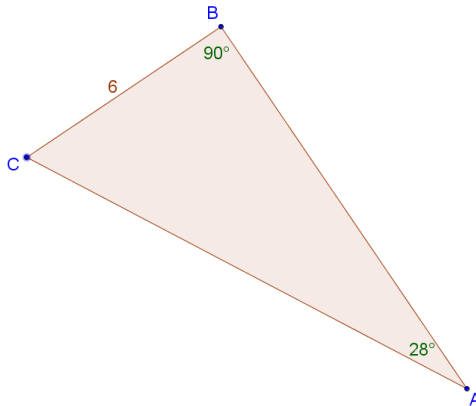
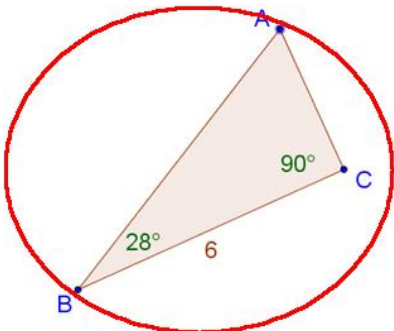

Discussion questions: What if you only have three pieces of information about a triangle, like two angle measurements and one side length? Is it possible to create more than one unique triangle with that information?

Materials: GeoGebra and 5.2 GeoGebra files (The GeoGebra links are on the teacher and student support sites at utahmiddleschoolmath.org). You may also do this activity with concrete manipulatives.

Instructions: Open the file. Read the criteria that your triangle must satisfy. Drag the pieces to carefully form a triangle with the information required. If no triangle is possible, explain why. If only one triangle is possible, draw it and measure the remaining sides and angles using the tools in the program. If there is more than one way to make the triangle, draw both triangles.

Trial #1: SSS How many different triangles?	Draw the triangle(s), or write why no triangle is possible. One possible triangle.
Trial #2: SAS How many different triangles?	Draw the triangle(s), or write why no triangle is possible. One possible triangle.
Trial #3: ASA How many different triangles?	Draw the triangle(s), or write why no triangle is possible. One possible triangle.
Trial #4: SSA How many different triangles?	Draw the triangle(s), or write why no triangle is possible. More than one. Note that given two sides and an angle that is not included there <i>may</i> be up to two triangles possible, but never more than 2.
Trial #5: AAS How many different triangles?	Draw the triangle(s), or write why no triangle is possible. One possible.

Discussion notes: Notice that all the above examples included a side. Ask students about AAA (and then by extension AA.) No, three angles do not guarantee we will create a unique triangle—though all triangles created will have the same shape (similar.) Note too that one only needs 2 angles for the same shape; once you have two angles, the third is automatically determined.

Spiral Review

1. $-8 = -3m + 10$ $m = 6$

2. $-12 = 3x$ $x = -4$

3. Write $\frac{3}{5}$ as a percent and decimal. 60% , 0.6

4. Show how to simplify the following expression with a number line $-6 + (-3)$ -9

5. Kurt earned \$550 over the summer. If he put 70% of his earnings into his savings, how much money did he have left over?

$$550(1 - 0.70) = \$165 \quad \text{or} \quad 550 - 385 = 165$$

5.1b Homework: Building Triangles Given Three Measurements

- Use the grid below to draw and label $\triangle ABC$ with the length of \overline{AB} 5 units, the length of \overline{BC} 7 units, and the measure of $\angle ABC = 90^\circ$.

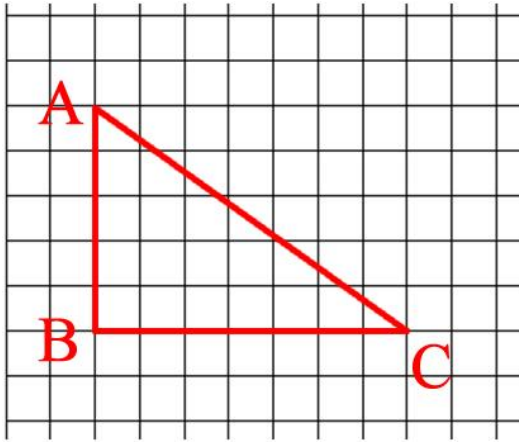

- Is $\angle ABC$ the *included* angle to the given sides? Explain.
- What is the area of the triangle in #2? Justify your answer.
- Will all your classmates who draw a triangle like #2 get a triangle with the same area? Explain.
- Which triangle(s) has two sides 5 and 8 units, and a non-included angle of 20° adjacent to the side of length 8?

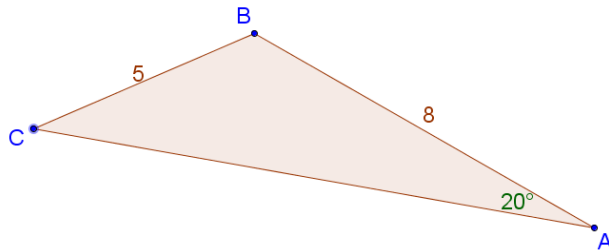
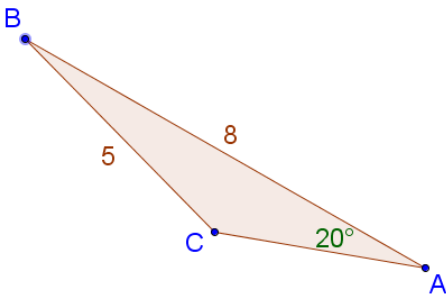

- Are the two triangles in #5 exactly the same and size and shape?
No, because $\angle ABC$ is not the same in both triangles.

For #7-13, decide whether there are 0, 1, or more than one possible triangles with the given conditions. Use either a ruler and protractor, graph paper strips and protractor, or GeoGebra to draw the triangles.

<p>7. A triangle with sides that measure 5, 12, and 13 cm.</p> <p>How many possible triangles?</p> <p>One</p> <p>If possible, what kind of triangle? Sketch, label.</p>	<p>8. A triangle with sides that measure 4 and 6, and an included angle of 120°.</p> <p>How many possible triangles?</p> <p>If possible, what kind of triangle? Sketch, label.</p>
<p>9. A triangle with angles 100° and 20°, and an included side of 2.</p> <p>How many triangles?</p> <p>If possible, what kind of triangle? Sketch, label.</p>	<p>10. A triangle with two angles of 40° and 30°, and an included side of 6.</p> <p>How many triangles?</p> <p>One</p> <p>If possible, what kind of triangle? Sketch, label.</p>

<p>11. A triangle with two sides of 5 and 7, and an included angle of 45°.</p> <p>How many triangles?</p> <p>If possible, what kind of triangle? Sketch, label.</p>	<p>12. A triangle with angles of 30° and 60°, and a non-included side of 5 units adjacent to the 60° angle.</p> <p>How many triangles?</p> <p>One</p> <p>If possible, what kind of triangle? Sketch, label.</p>
<p>13. A triangle HIJ in which $m \angle HIJ = 60^\circ$, $m \angle JHI = 90^\circ$, and $m \angle IJH = 55^\circ$.</p> <p>How many possible triangles?</p> <p>None</p> <p>If possible, what kind of triangle? Sketch, label.</p>	<p>14. A triangle ABC in which $AB = 3$ cm., $m \angle ABC = 60^\circ$, and $m \angle BCA = 60^\circ$.</p> <p>How many possible triangles?</p> <p>If possible, what kind of triangle? Sketch, label.</p>
<p>15. Paul lives 2 miles from Rita. Rita lives 3 miles from the shopping mall. What are the shortest and longest distances Paul could live from the mall?</p> <p>(Whole number solutions) (Rational solutions)</p> <p>Draw and explain.</p>	

5.1c Class Activity: Sum of the Angles of a Triangle Exploration and 5.1 Review

Activity: Cut out 5 *different* triangles. Mark the angles and then tape them together as shown below. Use a protractor to find the measure of the sum of the angles and fill in the table.

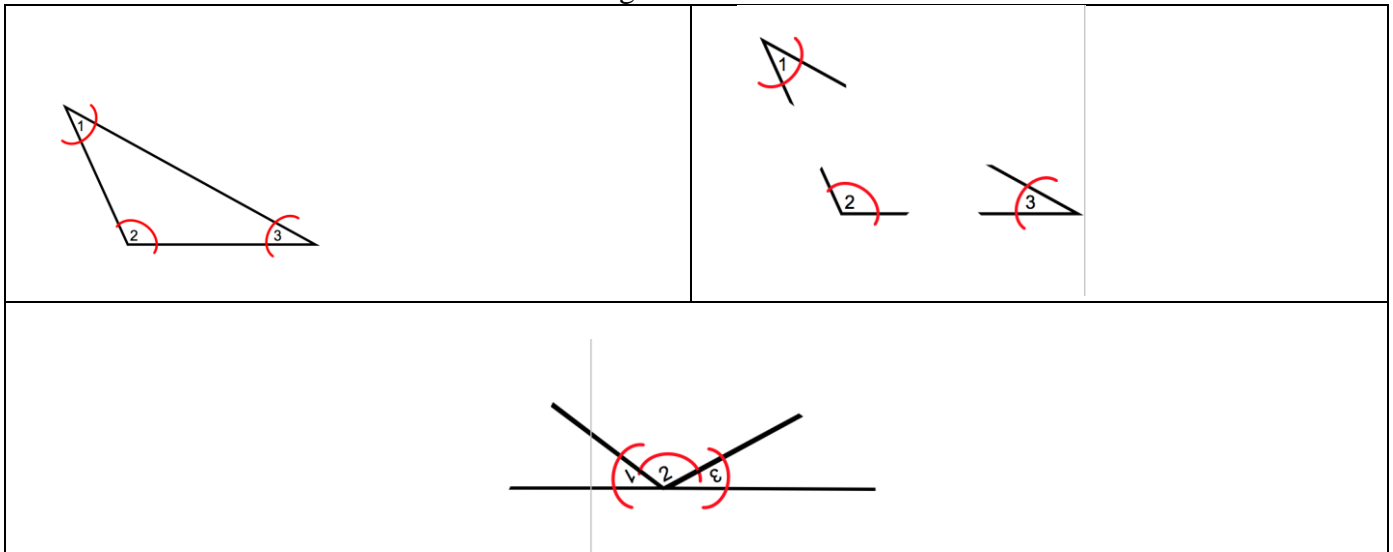

Type of Triangle	Sum of Angles

5.1c Honors Extension: Sum of the Angles of a Polygon Exploration

Activity: Cut out 5 *different* triangles, quadrilaterals, pentagons, and hexagons (all convex). Mark the angles and then tape them together. Use a protractor to find the measure of the sum of the angles and fill in the table.

POLYGON	Number of Angles	Sum of Angles
Triangle	3	180°

Try this activity before you do it with students. You will notice that when you tape together the angles of a triangle, you will form a straight line. If you tape together the angles of a quadrilateral, the angles will sum to 360 degrees (some students will say “a circle.”) To do a pentagon, you’re going to have to “overlap.” E.G. As you join your angles, you’ll go past 360 to 540 degrees.

1) What pattern do you notice?

Allow students to explore. They should see that there is a pattern with 180 degrees. Some students may notice that odd number sided polygons end in “lines” whereas even sided polygons end in “circles.” There is no need to push for $180(n-2)$ as a formula, though you want them to articulate that concept in words and then use it as they check an octagon.

2) What do you expect the sum of the angles of an OCTAGON will be?

- 3) Cut out a convex octagon and test your conjecture.

- 4) Cut out a triangle and quadrilateral. Trace out the triangle on to a piece of grid paper. After you have traced it, rip the corners off and try to construct as many new triangles as you can with the original angles. Do the same with the quadrilateral. What do you notice?

Students will need grid paper for this activity. They should note that for a triangle, they can construct infinitely many triangles with the original angles and each of the new triangles will be the same shape but different sizes from the original. However, the angles of the quadrilateral can create quadrilaterals that are the same shape but different sizes of the original OR they might create quadrilaterals that are not the same shape (for example, four right angles can create infinitely many squares; or they can create infinitely many rectangles.) The discussion will lead to ideas that will be developed in #5.

- 5) Predict the sum of the angles of a 10-agon.

Spiral Review

1. $5 \times (-11)$ **-55**

2. Without a calculator, what percent of 80 is 60?. **75%**

3. Find the following with or without a model:

$26 + (-26) = 0$ (additive inverse)

$\frac{1}{6} + \frac{3}{7} = \frac{7}{42} + \frac{18}{42} = \frac{25}{42}$

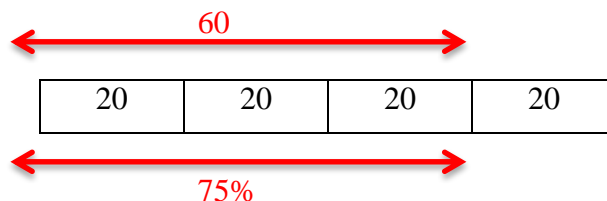

4. Order the numbers from least to greatest.

$-2.15, \frac{17}{7}, 2.7, -2.105$ **$-2.15, -2.105, \frac{17}{7}, 2.7$**

5. Given the following table, find the indicated unit rate:

Days	Total Push-ups
2	30
4	60
29	435

_____ **15** push-ups per day

5.1c Homework: Sum of the Angles of a Triangle Exploration and 5.1 Review

- Determine whether the three given side lengths can form a triangle. If not, explain why it doesn't work.
 - 5.1 inches, 3.24 inches, 8.25 inches
 - $4\frac{1}{2}$ cm, $3\frac{3}{4}$ cm, 8 cm
 - 6.01 cm, $5\frac{1}{4}$ cm, 11.22 cm
 - $4\frac{1}{2}$ m, $3\frac{1}{4}$ m, 8 m
- Your friend is having a hard time understanding how angle measures of 30° , 60° , 90° might create more than one triangle. Draw two different triangles that have those angle measures and explain why the two triangles are different.
- Your friend is having a hard time understanding why knowing the lengths of two sides of a triangle and the measure of an angle not between the two sides may not be adequate information to construct a unique triangle. Draw an example where two sides and a non-included angle give two different triangles.

5.1d Self-Assessment: Section 5.1

Consider the following skills/concepts. Rate your comfort level with each skill/concept by checking the box that best describes your progress in mastering each skill/concept. Sample problems can be found on the following page.

Skill/Concept	Beginning Understanding	Developing Skill and Understanding	Practical Skill and Understanding	Deep Understanding, Skill Mastery
1. Given specific criteria, construct a triangle and know if it's a unique triangle	I don't know what information I need to make a unique triangle. Nor do I know how to work with information given to me.	I can usually construct a triangle with information given, but I don't always know if the triangle is unique or if I'll even get a triangle by just looking at the information.	I can tell if the information given will make a triangle and I can construct it. I also know if the triangle I constructed is the only one I can construct from the information	I can tell if the information given will make a triangle and I can construct it. I also can explain why the information gives a triangle and why it is or is not unique.
2. Understand and explain the side length requirements of a triangle.	I struggle to understand how and when length will or will not make a triangle.	I can determine if lengths given will make a triangle.	I can determine if lengths given will make a triangle and can apply that knowledge to contexts.	I can determine if lengths given will make a triangle and can apply that knowledge to contexts. I can also explain in my own words why lengths will or will not form a triangle.
3. Understand and explain the angle and side requirements for constructing a unique triangle.	I struggle to understand the angle and side requirements for constructing a unique triangle.	I can determine if the sides and angles given will make a unique triangle.	I understand the angle and side requirements for constructing a unique triangle and can use it to explain whether or not given sides and angles will make a unique triangle.	I understand and can explain the angle and side requirements for constructing a unique triangle. I can explain in my own words why some will not necessarily make a unique triangle.
4. Know the angle measure requirements of a triangle. (Triangle Angle Sum Theorem)	I don't know what the sum of the angles of a triangle is.	Given three angles, I know if they will make a triangle OR given two angles of a triangle, I can figure out the third.	Given three angles, I know if they will make a triangle OR given two angles of a triangle, I can figure out the third. I can use this knowledge in context as well.	Given three angles, I know if they will make a triangle OR given two angles of a triangle, I can figure out the third. I can use this knowledge in context as well. I can explain in my own words what this all works.

Sample Problems for Section 5.1

1. Given the following criteria, construct a triangle:
 - a. Draw and label $\triangle ABC$ with the length of \overline{AB} 5 units, the length of \overline{BC} 7 units, and the length of \overline{CA} 10 units.
 - b. Draw and label $\triangle ABC$ with the measure of $\angle CAB = 40^\circ$, the measure of $\angle BCA = 50^\circ$, and the measure of $\angle ABC = 90^\circ$.
 - c. Draw and label $\triangle ABC$ with the measure of $\angle CAB = 60^\circ$, the length of \overline{CA} 4 units, and the length of \overline{BA} 6 units.
2. Determine if the following side lengths will make a triangle. Explain why or why not.
 - a. 2, 5, 7
 - b. 33, 93.2, 70
 - c. 1, 2.7, 7
3. Determine if the given information will make a unique triangle. Explain why or why not.
 - a. Side lengths 3 and 5 and an included angle of 67°
 - b. Angles 73° , 7° , 100°
 - c. Angles 80° and 25° and included side of 12
4. Determine if the given angles will make a triangle. Explain why or why not.
 - a. Angles 25° , 70° , 95°
 - b. Angles 30° , 40° , 20°

Section 5.2: Scale Drawings

Section Overview: The central idea of this section is scale and its relationship to ratio and proportion. Students will use ideas about ratio, proportion, and scale to: a) change the size of an image and b) determine if two images are scaled versions of each other.

By the end of this section, each student should understand that we could change the scale of an object to suit our needs. For example, we can make a map where 1 inch equals one mile; lie out a floor plan where 2 feet equals 1.4 cm from a diagram; or draw a large version of an ant where 3 centimeters equals 1 mm. In each of these situations, the “shape characteristics” of the object remain the same, what has changed is size. Objects can be scaled up or scale down. Through explorations of scaling exercises, students will see that all lengths of the given object are changed by the same factor in the scaled representation and this factor is called the *scale factor*.

The term “similar” will not be defined in 7th grade; here students continue to develop an intuitive understanding of “the same shape,” so that the concept of similarity (introduced in 8th grade) is natural. Throughout this section students should clearly distinguish between two objects that are of the same shape and dimension and objects that are scaled versions of each other. In particular students will come to understand that two polygonal figures that are scaled versions of each other have equal angles and corresponding sides in a ratio of $a:b$ where $a \neq b$. Students should also distinguish between saying the *ratio* of object A to object B is $a:b$ while the *scale factor* from A to B is b/a . This idea links ratio and proportional thinking to scaling.

Students will learn to find the scale factor from one object to the other from diagrams, values and/or proportion information. Students should be able to fluidly go from a smaller object to a larger scaled version of the object or from a larger object to a smaller scaled version giving either or both the proportional constant and/or the scale factor.

In this section and through the chapter, abstract procedures will be emphasized for finding scale factors and/or missing lengths, however some students may prefer to continue to use bar models. Bar model strategies will become increasingly more cumbersome, so it will be important to help students transition to more efficient procedures. This can be done by helping students connect concrete models (i.e. bar/tape models) to the algorithmic procedure as was done in Chapter 4.

Concepts and Skills to be Mastered (from standards)

Geometry Standard 1: Solve problems involving scale drawings of geometric figures, including computing actual lengths and areas from a scale drawing and reproducing a scale drawing at a different scale. 7.G.1

Geometry Standard 6: Solve real-world and mathematical problems involving area, volume and surface area of two- and three-dimensional objects composed of triangles, quadrilaterals, polygons, cubes, and right prisms. 7.G.6

1. Draw a scaled version of a triangle, other polygon, or other object given lengths.
2. Find a measure of a scaled object given the scale factor and measure from the original.
3. Find the scale factor between two objects that are the same shape but different sizes/proportional.
4. Use proportional reasoning in explaining and finding missing sides of objects that are the same shape but different sizes.
5. Find the scale factors for perimeter or area for proportional objects.

5.2a Classwork: Comparing the Perimeter and Area of Rectangles

Activity 1: Below is an image of a rectangle, which are 4 units by 6 units. On the first grid provided, draw a rectangle with sides lengths TWICE as long as this image (label the new vertices E, F, G, H) and on the other grid draw a rectangle with side lengths HALF as long as this image (label the new vertices I, J, K, L.)

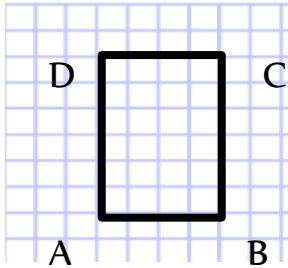

- Describe the method you used to double the length of each side.
Students will use a variety of methods. Highlight methods that involve “slope thinking”; e.g. a student might say, “to get from A to C, you go up 4 and right 2, so to double that length, I went up 8 and right 4.”
Students may just say, “AB is 4 units, so the new side must be 8.”
- Describe the method you used to make each side have a length half the length of the original.
- Do you think the area of the new rectangles changes at the same rate as the sides? Explain. *Area is squared when side lengths are doubled.*

Sides that are twice as long as the image above.

Sides that are half as long as the image above.

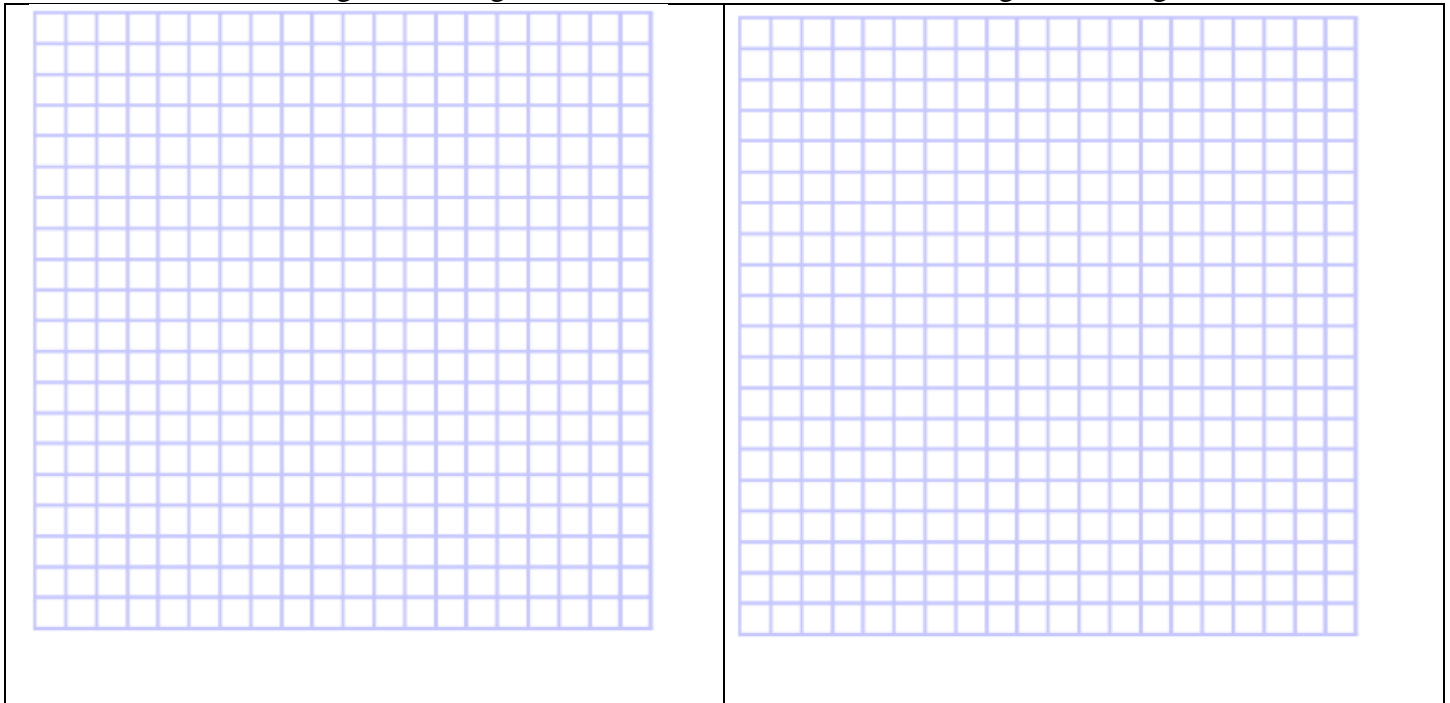

Fill out the missing blanks in the chart below:

Rectangle	Dimensions	Perimeter	Area	Change from original rectangle ABCD
ABDC	4×6	20	24	Same
EFGH	8×12	40	96	Dimensions double, perimeter doubled, area quadrupled (times 4)
IJKL	2×3	10	6	Dimensions half, perimeter half, area divided by 4

Activity 2: Below is an image of a rectangle which is *3 units by 5 units*. On the first grid provided, draw a rectangle with sides lengths **TWICE** as long as this image (label the new vertices Q, R, S, T) and on the other grid draw a rectangle with side lengths **HALF** as long as this image (label the new vertices U, V, W, X).

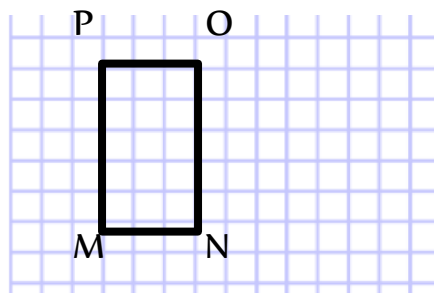

Sides that are twice as long as the image above.

Sides that are half as long as the image above.

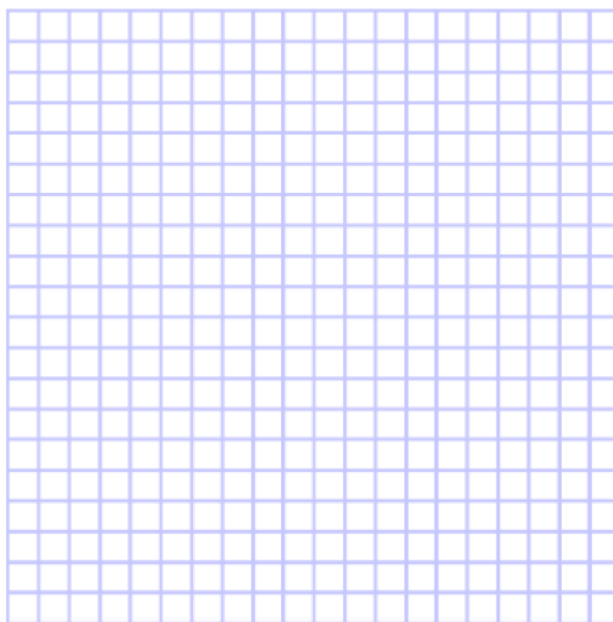

Fill in the missing blanks in the chart below:

Rectangle	Dimensions	Perimeter	Area	Change from original rectangle ABCD
MNOP	3×5	16	15	Same
QRST				
UVWX	1.5×2.5	4	3.75 or $15/4$	Dimensions half, perimeter half, area divided by 4

Discuss that if lengths are doubled, the new area changes by 2^2 times the original (old) area; if lengths are divided by 2 (multiplied by $(1/2)$), the new area is $(1/2)^2$ the original (old) area.

Spiral Review

1. What are triangles with all sides the same length called? Equilateral triangles
2. Katherine is visiting patients in a hospital. She visits 18 patients in 6 hours. At that rate, how many patients will she visit in 9 hours?

hours	Patients visited
6	18
9	27

3. What is an obtuse angle? **An angle whose measure is 90 degrees $<$ angle measure $<$ 180 degrees**
4. The price for two bottles of ketchup are given below:

A 20 oz. bottle of DELIGHT ketchup is 98¢ at the grocery store. A 38 oz. bottle of SQUEEZE ketchup is \$1.99 at the same grocery store.

- a) find the unit rate for each product

DELIGHT is \$.049 per ounce SQUEEZE is \$.052 per ounce

- b) What conclusions can you draw from this information?

DELIGHT is the least expensive of the two.

5.2a Homework: Comparing the Perimeter and Area of Rectangles

Below is a table that describes the dimensions, perimeter, area and change of side lengths for a rectangle that's scaled in different ways. In the first row you find that the 5x20 rectangle has a perimeter of 50, area of 100; there is no change in side length here because it's the original rectangle. In the next row the dimensions become 10x40 giving it a perimeter of 100 and area of 400; the side length change is twice the original. Examine the other rows to understand what's happening to the rectangle. Then graph the relationship between the perimeter (x axis) and area (y axis) on the graph below. Describe the pattern you notice.

Dimensions	Perimeter	Area	Change of side lengths from original rectangle
5 by 20	50	100	Same
10 by 40	100	400	Twice
5/2 by 10	25	25	Half
15 by 60	150	900	Three times
5/3 by 20/3	16.67	11.11	One third
20 by 80	200	1600	Four times

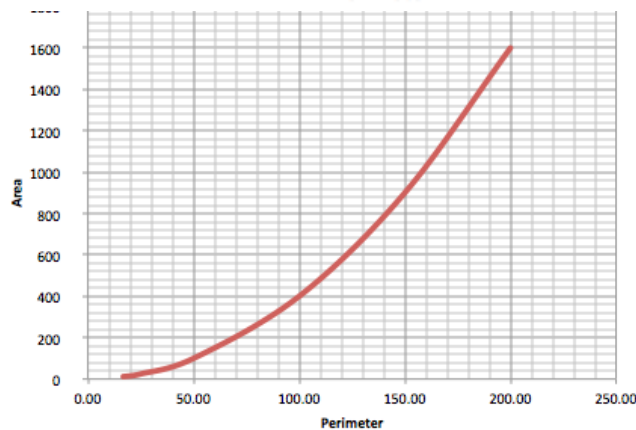
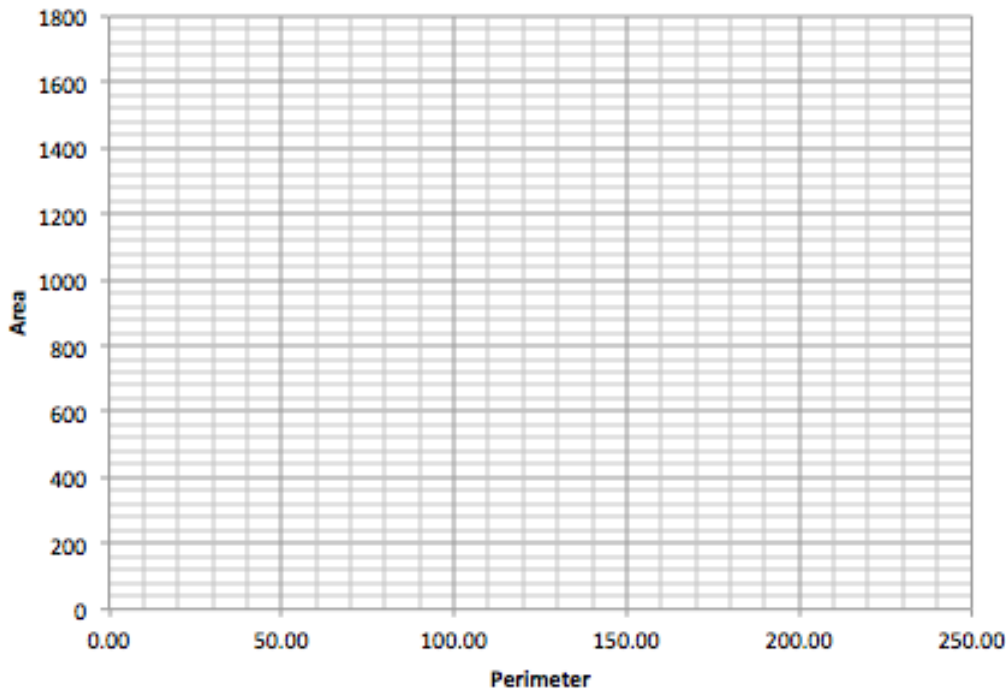

Students should notice that the relationship is not linear. Other ideas may also surface.

5.2b Classwork: Scaling Triangles

Activity 1: Below is an image of a triangle. On the first grid provided, draw a triangle with sides lengths TWICE as long as this image (label the new vertices D, E, F) and on the other grid draw a triangle with side lengths HALF as long as this image (label the new vertices G, H, I.)

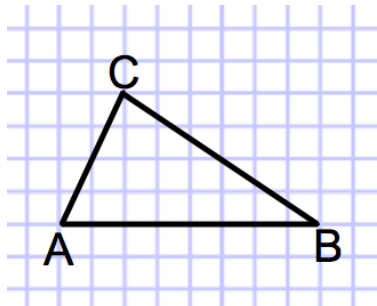

- Describe the method you used to double the length of each side.
Students will use a variety of methods. Highlight methods that involve “slope thinking”; e.g. a student might say, “to get from A to C, you go up 4 and right 2, so to double that length, I went up 8 and right 4.”
- Describe the method you used to make each side have a length half the length of the original.
- Do you think the angles of the new triangles are the same or different than the original triangle? Explain. Angles are preserved.

Sides that are twice as long as the image above. Sides that are half as long as the image above.

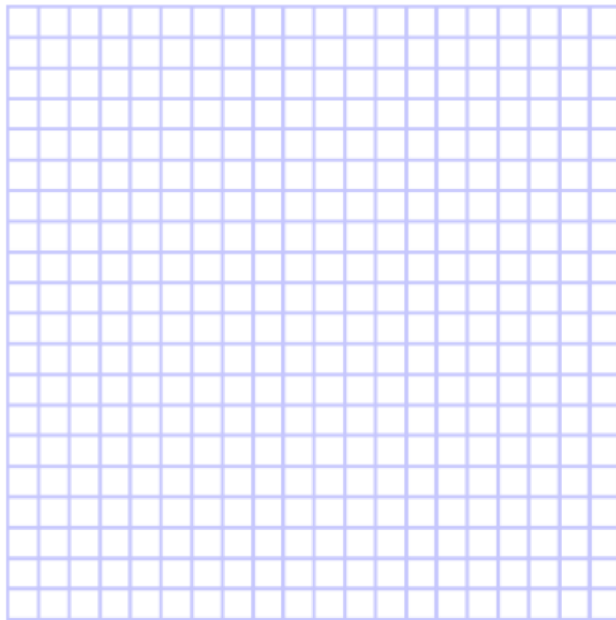
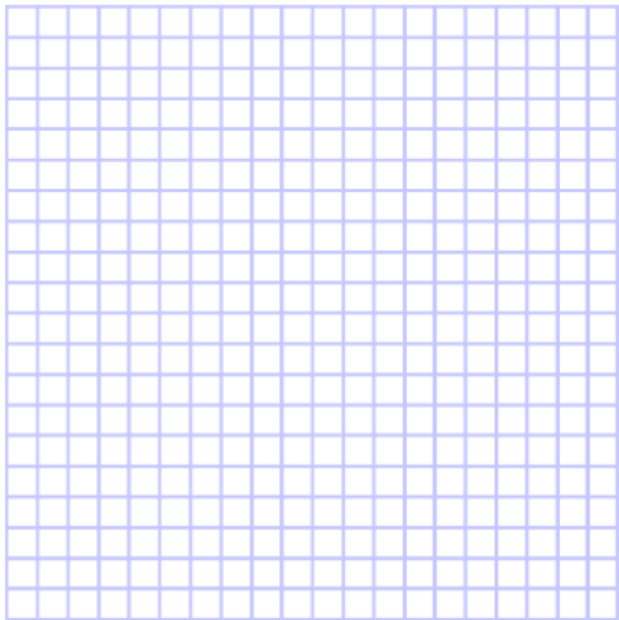

Discuss with students that as with rectangles, when the lengths of sides are doubled, the new perimeter doubles, and the new area is quadruple the original area; when lengths of sides are multiplied by $(1/2)$ the new perimeter will be $(1/2)$ the original and the new area will be $(1/2)^2$ the original.

Eventually you want students to understand that when sides are scaled by a factor of a , the new perimeter is a times the original perimeter and the new area is a^2 time the original area.

Activity 2: Exploring the relationship between triangles that have the same angle measures but side lengths that are different.

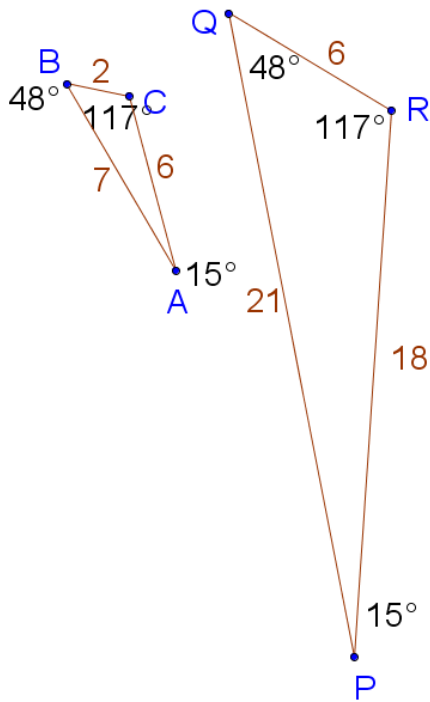

Which sides and angles correspond to each other? List corresponding angles and sides:

$\angle ABC (48^\circ)$ and $\angle PQR (48^\circ)$
 $\angle BCA (117^\circ)$ and $\angle QRP (117^\circ)$
 $\angle CAB (15^\circ)$ and $\angle RPQ (15^\circ)$

$\overline{AB} (7)$ and $\overline{PQ} (21)$

$\overline{BC} (2)$ and $\overline{QR} (6)$

$\overline{CA} (6)$ and $\overline{RP} (18)$

a) Describe how these triangles are similar and different:

b) What do you notice about the lengths of the sides of the two triangles? **Corresponding sides have the same ratio. The ratio of the sides is 1:3 little:big. However, to find the length of a side on the larger triangle, one multiplies the corresponding side of the smaller triangle by 3. Said another way, the ratio of little:big is 1:3 but the scale factor from the little to big is 3. This is an important point, be sure to emphasize it.**

Look back at Activity 1 in this section. Write the ratio of the original triangle to the triangle with side lengths that are twice the original and then write the ratio of the original triangle to the triangle with side lengths that are half as long as the original. .

Clarify for students the difference between “ratio” and “scale factor.” e.g. in Activity 1 the ratio between the sides of original to twice the length is 1 : 2. However the scale factor is 2. In other words, one multiplies each length of the original by 2 to get the larger triangle. For the original:half the ratio is 1:1/2 but the scale factor is 1/2.

3. Find the ratios for the lengths of the given sides.

a) \overline{BC} to \overline{QR} $\frac{2}{6}$ or $\frac{1}{3}$ or 1 to 3	b) \overline{AB} to \overline{PQ} $\frac{7}{21}$ or $\frac{1}{3}$ or 1 to 3
c) \overline{AC} to \overline{PR} $\frac{6}{18}$ or $\frac{1}{3}$ or 1 to 3	d) Perimeter of $\triangle ABC$ to Perimeter of $\triangle PQR$ $\frac{15}{45}$ or $\frac{1}{3}$ or 1 to 3
e) \overline{BC} to \overline{AB} $\frac{2}{7}$ or 2 to 7	f) \overline{QR} to \overline{QP} $\frac{6}{21}$ or $\frac{2}{7}$ or 2 to 7
g) \overline{AC} to \overline{BC} $\frac{6}{2}$ or 3 or 3 to 1	h) \overline{RP} to \overline{QR} $\frac{18}{6}$ or 3 or 3 to 1
i) \overline{AC} to \overline{AB} $\frac{6}{7}$ or 6 to 7	j) \overline{RP} to \overline{QP} $\frac{18}{21}$ or $\frac{6}{7}$ or 6 to 7

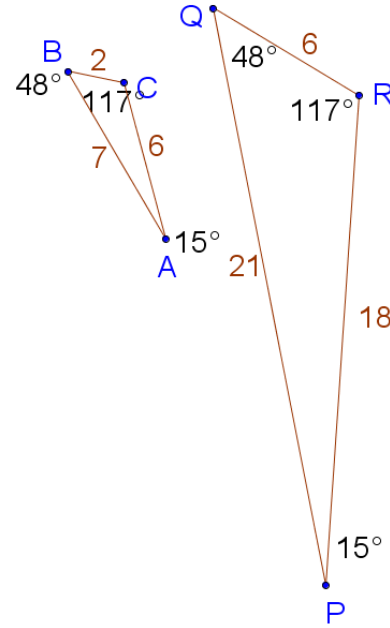

4. Some of the ratios above make comparisons of measurements in the **same triangle**. Other ratios make comparisons of measurements of corresponding parts of **two different triangles**. Put a star by the ratios that compare parts of two different triangles. What do you notice? **a, b, c, d. The ratios are all the same.**

5. Since the corresponding parts have the same ratio, there is a **scale factor** from $\triangle ABC$ to $\triangle PQR$. The scale factor is the number you would multiply a length in $\triangle ABC$ to get the corresponding length in $\triangle PQR$. What is the scale factor from $\triangle ABC$ to $\triangle PQR$? Explain how you arrived at your answer.

3

6. What is the scale factor from $\triangle PQR$ to $\triangle ABC$? **$\frac{1}{3}$**

7. What is the mathematical relationship between the scale factor of $\triangle PQR$ to $\triangle ABC$ and the scale factor of $\triangle ABC$ to $\triangle PQR$? **they are reciprocals.**

8. The scale factors from $\triangle ABC$ to $\triangle PQR$ is an *enlarging* scale factor, and the other is a *reducing* scale factor. What would be the scale factor to keep a figure the *same size*?

Discuss with students: You can set ratios of corresponding pairs of parts equal to solve for unknown lengths. As we did when writing proportions in chapter 4, *make sure you make like comparisons*. You can use comparisons of two parts of the same triangle, or comparisons of corresponding parts in different triangles, as long as you are consistent in order of the comparison of the two ratios.

9. Use a straight edge and protractor to construct $\triangle ABC$ then construct a new triangle, $\triangle DEF$, that is the same shape as $\triangle ABC$, but the scale factor from $\triangle ABC$ to $\triangle DEF$ is 2. Help students notice that 2 is an *enlarging* scale factor. The sides of the new triangle will be 6, 12.4 and 8.

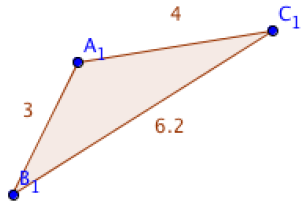

Discuss with students the notion of “unit.” In #9, the line segment from A to B can be thought of as a unit. That length, regardless of how one measures it (inches, centimeters, millimeters, etc.), needs to double for the new triangle because the scale factor is 2. Similar reasoning for the other two sides.

10. If the ratio of $\triangle HIJ$ to $\triangle DEF$ is $\frac{4}{3}$, (see $\triangle HIJ$ below), draw $\triangle DEF$. Show the length of each of the sides.

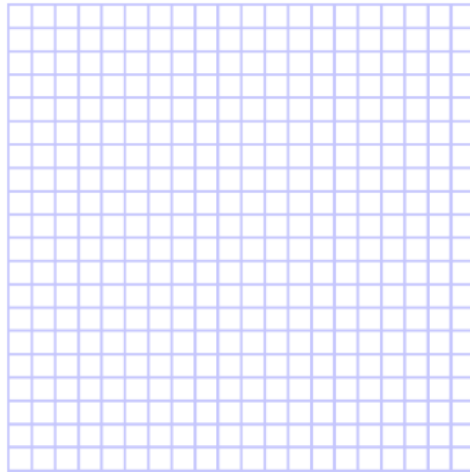
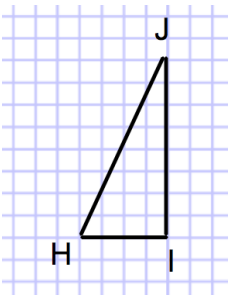

There are three ways a student might think about the relationship: 1) because the ratio is $\frac{4}{3}$, we know the scale factor is $\frac{3}{4}$ (the reciprocal.) So we multiply the length of each side of the original triangle by the scale factor $\frac{3}{4}$ to get the length of the new triangle. Length of HI is 4, so for the new triangle it will be $4 \times (\frac{3}{4})$ or 3. 2) Write a proportion equation: for HI original/new = $\frac{4}{3} = \frac{4}{x}$; for IJ original/new = $\frac{4}{3} = \frac{8}{x}$ and solve. 3) Each side of the original can be divided into 4 equal parts and then take 3 for the new figure.

Also connect the idea of SAS—once we have the two sides and know that the included angle is 90 degrees, we can construct a unique triangle.

11. The ratio of $\triangle ABC$ to $\triangle DEF$ is 5:4. If \overline{BC} is 15, what is the length of \overline{EF} ? You may need to draw a diagram.

12

12. The two triangles below are scaled versions of each other. Use a protractor to find the measure of each of the angles of the two triangles below.

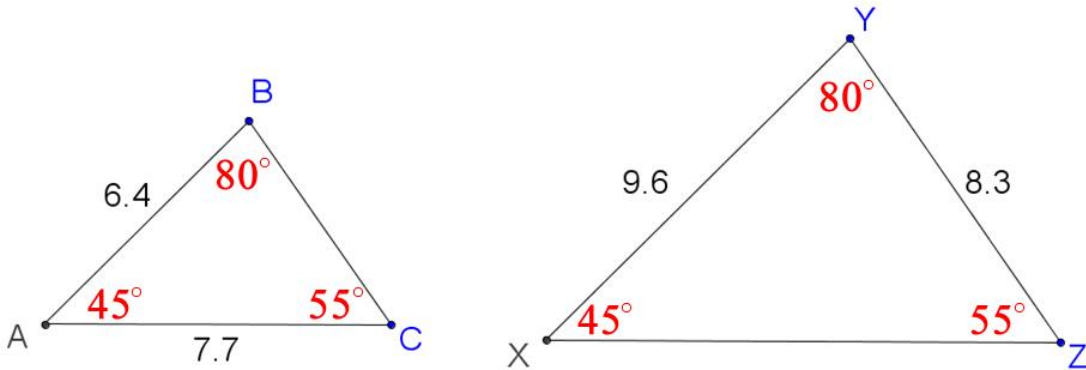

13. What is the ratio of $\triangle ABC$ to $\triangle XYZ$? What is the scale factor that takes $\triangle ABC$ to $\triangle XYZ$?

Ratio is 2:3 and scale factor is 3/2

14. Which of the following proportions would be valid for finding the length of \overline{BC} ? Circle all that apply.

a. $\frac{9.6}{6.4} = \frac{8.3}{BC}$

a and c. Stress the importance of parallel structure when setting up proportions.

b. $\frac{6.4}{BC} = \frac{8.3}{9.6}$

c. $\frac{6.4}{BC} = \frac{9.6}{8.3}$

d. $\frac{BC}{7.7} = \frac{8.3}{9.6}$

15. Write different proportions that could be used to solve for the length of \overline{BC} . Solve your proportion.

16. Write and solve a proportion to find the length of \overline{XZ} .

$\overline{XZ} = 11.55$

Spiral Review

1. Suppose you were to flip a coin 3 times. What is the probability of getting heads all three times? $\frac{1}{8}$
2. Samantha has 120 bracelets. She sells $\frac{2}{3}$ of the bracelets and then decides to donate 50% of the rest.. How many bracelets does she still have?

20

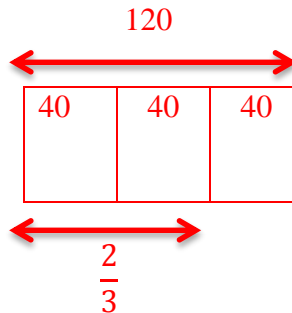

3. Place each of the following integers on the number line below. Label each point:

$$\mathbf{A = 4 \quad B = -4 \quad C = -15 \quad D = 7 \quad E = 18 \quad F = -19}$$

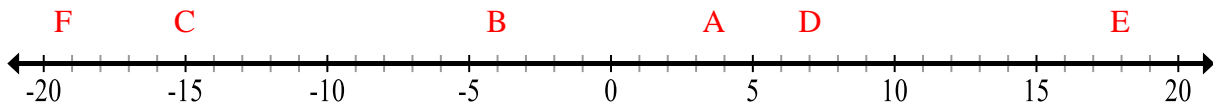

4. Write 0.672 as a percent. 67.2%

5.2b Homework: Scaling Triangles

1. The measure of each of the sides of $\triangle DEF$ is given. Draw a $\triangle GHI$ that has side lengths that are three times as long as $\triangle DEF$



2. If the ratio of $\triangle BCD$ to $\triangle EFG$ is 3:5 and the length of \overline{BC} is 6", what is the length of \overline{EF} ? Justify your answer.

For #3-4, the triangles given in each are proportional. Do the following: a) solve for the unknowns by using proportions and b) state the scale factor between the two triangles. Express all answers exactly. Figures are not necessarily drawn to scale. Show your work.

3.

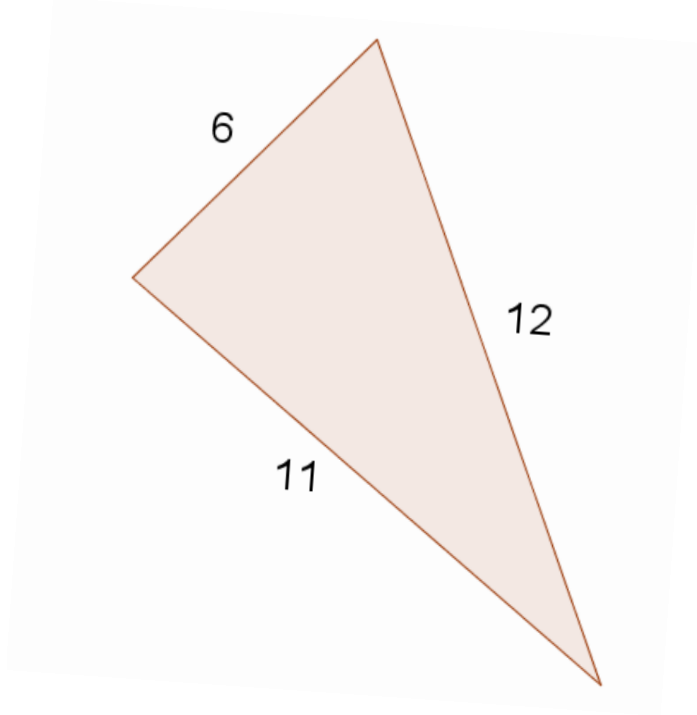
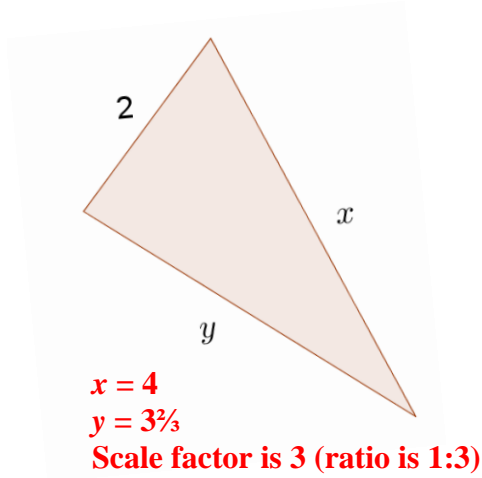

4.

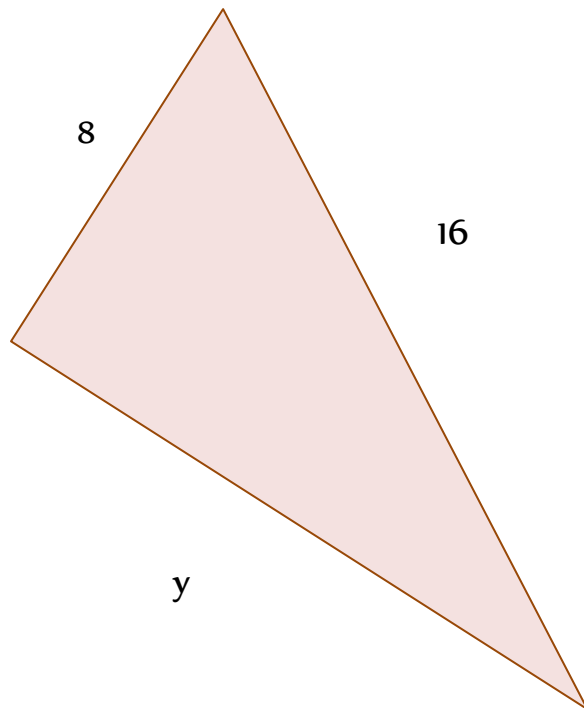
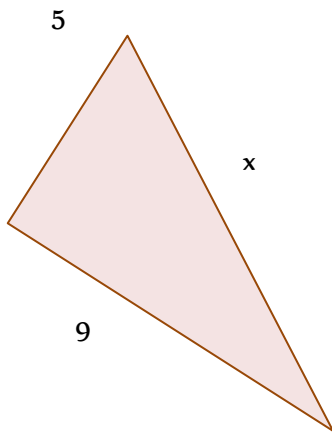

5.2c Class Activity: Solve Scale Drawing Problems, Create a Scale Drawing

1. Your sister wants a large poster version of a small drawing she made. She drew it on centimeter graph paper.

- a. What are the dimensions of her original picture as shown to the right?

8 cm × 6 cm

- b. She wants the poster version to have a height of at least 2 feet. What **scale** should she use so that her poster is 2 feet tall?

6 cm : 2 ft
 Height of original Height of large poster

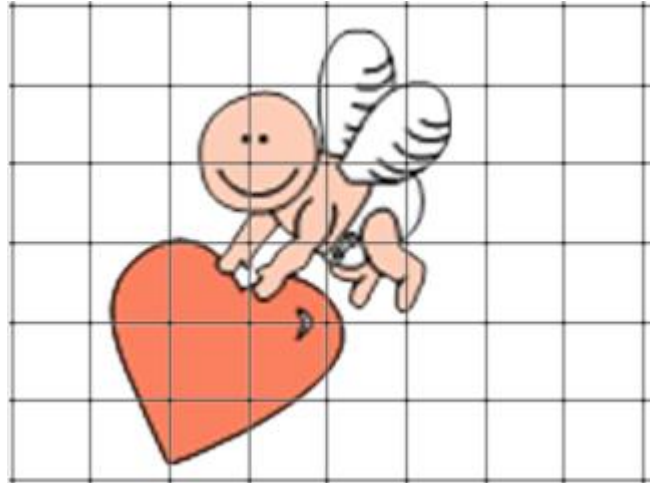

- c. The side of a square in the original picture is 1 cm long. How long will the side of a square be in the final poster? **4"** (Since 1 square is 1/6 of the height of the image, it should be 1/6 the height (24") of poster.)

Review: A scale drawing or a scale model results in an image where:

- the angles are all the same as the original, and
- the side lengths are all proportional to the original (have a common scale.)

- d. What will be the dimensions of the final poster?
2²/₃' x 2' or 32 inches wide by 24 inches high

1. Hal used the scale 1 inch = 6 feet for his scale model of the new school building. The actual dimensions of the building are 30 feet (height), by 120 feet (width) by 180 feet (length). What are the dimensions of his scale model?

5" x 20" x 30"

2. On a separate sheet of grid paper, create the creature below so that it is a 1:3 enlargement of the original model. Write your **strategy** for calculating lengths to the right of the picture.

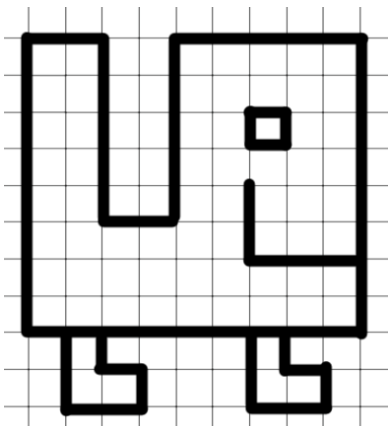

This will likely take about 10 minutes. Students may literally scale (for each unit of one on the original, they'll count out 3 on the scaled version) as they draw, or they may compute lengths and then draw.

3. Ellie was drawing a map of her hometown using a scale of 1 centimeter to 8 meters.
- The actual distance between the post office and City Hall is 30 meters. What is the exact distance between those two places on Ellie's map?

3.75 cm

- In her drawing, the distance from the post office to the library is 22 centimeters. What is the actual distance?

176 m

4. Allen made a scale drawing of his rectangular classroom. He used the scale $\frac{1}{2}$ inch = 4 feet. His actual classroom has dimensions of 32 feet by 28 feet.

- What are the dimensions of his scale drawing of the classroom?

4" x 3.5"

- The simplified unit ratio of **classroom length : drawing length**, written as a fraction, $\frac{\text{classroom length}}{\text{drawing length}}$, is the scale factor for lengths. What is it?

$\frac{8 \text{ feet}}{1 \text{ inch}}$ or $\frac{96}{1}$

- The simplified unit ratio of **classroom area : drawing area**, written as a fraction, $\frac{\text{classroom area}}{\text{drawing area}}$ is the scale factor for areas. What is it? **896 sq ft : 14 sq inches or 64 sq ft : 1 sq in. or**

$\frac{896 \text{ square feet}}{14 \text{ square inches}}$ or $\frac{64 \text{ square feet}}{1 \text{ square inch}}$ or $\frac{9216}{1}$

- What is the mathematical relationship between the scale factor for lengths and the scale factor for areas?

The scale factor of the areas is the same as squaring the scale factor of the lengths.

5. Audrey wants to make a scale drawing of the stamp below. She makes a scale drawing where 1 cm in the drawing represents 3 cm on the stamp. Which of the following are true?

- a. The drawing will be $\frac{1}{3}$ as wide as the stamp.
True
- b. The stamp will be 3 times as tall as the drawing.
True
- c. The area of the stamp will be 3 times as large as the drawing.
False
- d. The area of the stamp will be 6 times as large as the drawing.
False
- e. The area of the stamp will be 9 times as large as the drawing.
True



6. The following images are taken from four different maps or scale drawings, each shows a different way of representing scale:

Scale $\frac{1}{4}'' = 1 \text{ Foot.}$	Scale 1:10 (1 foot: 10 mm)
	drawing size = 1 inch real size = 1 meter

Which scale represents a drawing that has shrunk the most from the original? Justify your answer.

The 2 mile one

7. The scale of the drawing on the right is 1 unit = $\frac{1}{4}$ foot. Use the grid below to draw a new scale drawing where 1 unit = $\frac{1}{2}$ foot.

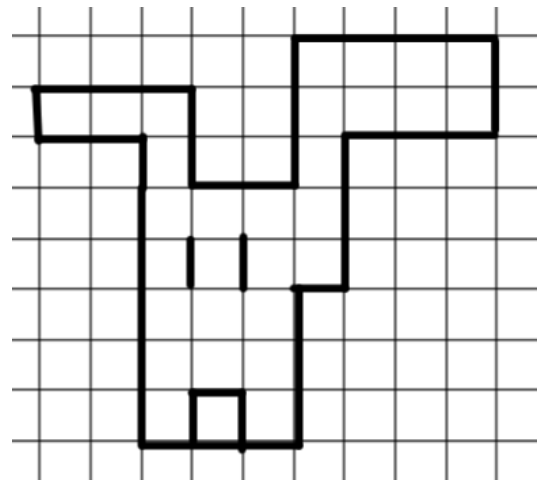

The grid below is purposely 4 times larger than the original to help illustrate the relationship.

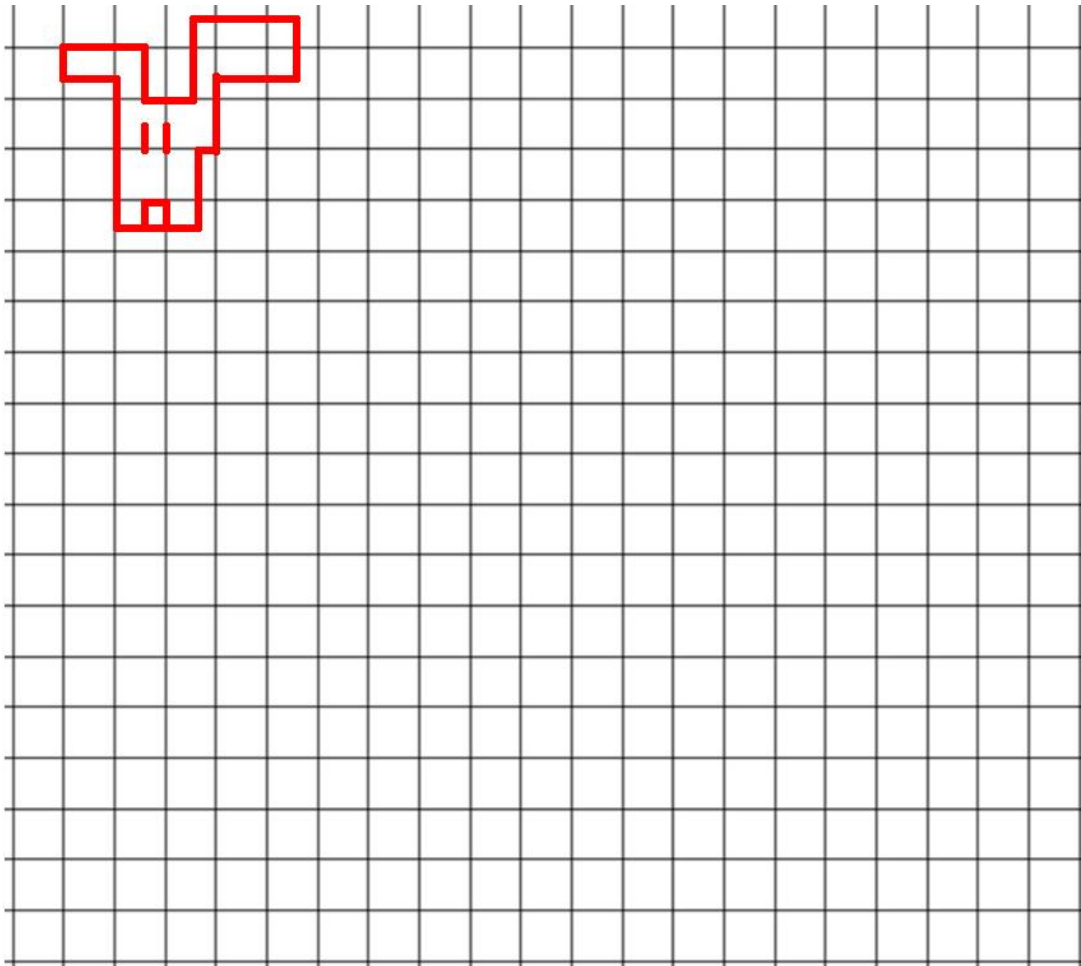

Notice that the width of the deer's head at its widest is four units. Because each unit in the original equals $\frac{1}{4}$ foot, thus the width is 1 foot. For the new scaled version, 1 unit = $\frac{1}{2}$ foot. To get a width of 1 foot, it will only need to be two units wide.

Spiral Review

- Suppose you flip a coin 3 times; what is the probability that you get a heads at exactly two times?
HHH, HHT, HTH, THH, TTT, TTH, THT, HTH $\frac{3}{8}$
- For each group of three side lengths in inches, determine whether a triangle is possible. Write yes or no. Justify your answer.
 - $14, 15\frac{1}{2}, 2$ **Yes**
 - $1, 1, 1$ **Yes**
 - $3.2, 7.2, 2.3$ **No, the sum of the two shorter sides is less than that of the longer side**
- Which number is greater: -24.41 or -24.4 ? Explain. **-24.4**

- Use long division to show how you can convert this fraction to a decimal and then a percent: $\frac{4}{7}$

$$\begin{array}{r} .571 \\ 7 \overline{) 4.00} \\ \underline{3 } \\ 50 \\ \underline{49} \\ 10 \\ \underline{07} \\ \end{array} \quad .571 \text{ or } .57, 57\%$$

- Athena has \$24 less than Bob. Represent how much money Athena has.
If b is the amount of money Bob has. Then Athena has $b - 24$ dollars.

5.2c Homework: Solve Scale Drawing Problems, Create a Scale Drawing

1. On a map, Breanne measured the distance (as the crow flies) between Los Angeles, California and San Francisco, California at 2 inches. The scale on the map is $\frac{1}{4} \text{ inch} = 43 \text{ miles}$. What is the actual straight-line distance between Los Angeles and San Francisco?

344 miles

2. Janie made a 2.5 inch scale model of one of the tallest buildings in the world: Taipei 101. The scale for the model is $\frac{1}{4} \text{ inch} = 167 \text{ feet}$. Find the actual height of Taipei 101.

3. What scale was used to enlarge the drawing below? How do you know?

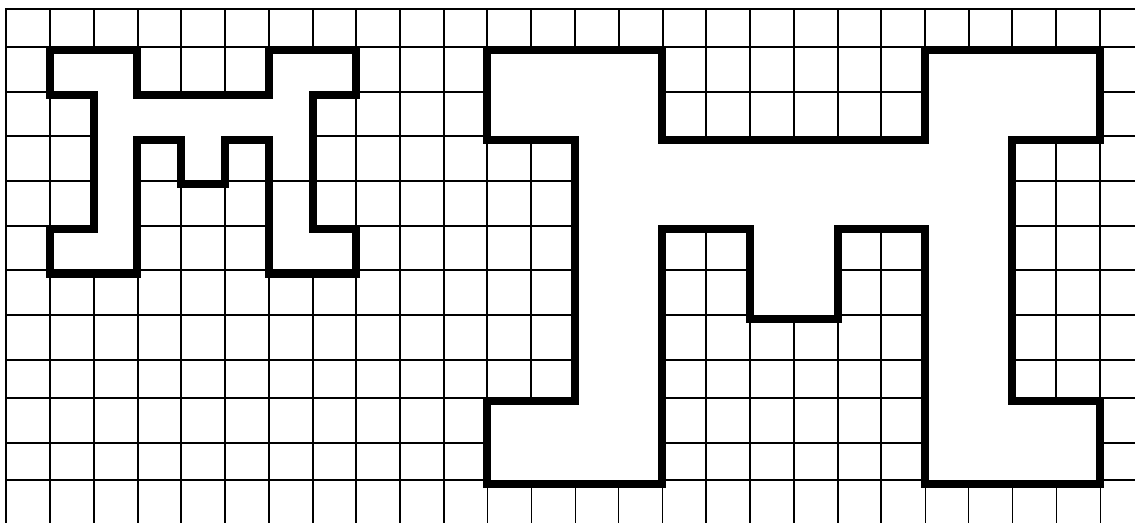

4. On the 0.25 inch grid below, create a scale drawing of a living room which is 9 meters by 6.25 meters. In the scale drawing include the following:
- a. Two windows on one of the walls. Each window is 1.25 meters wide.
 - b. An entrance (1.5 meters wide) from the side opposite the windows.
 - c. A sofa which is 2 meters long and 0.75 meters wide.
 - c. Record the drawing scale below the grid.

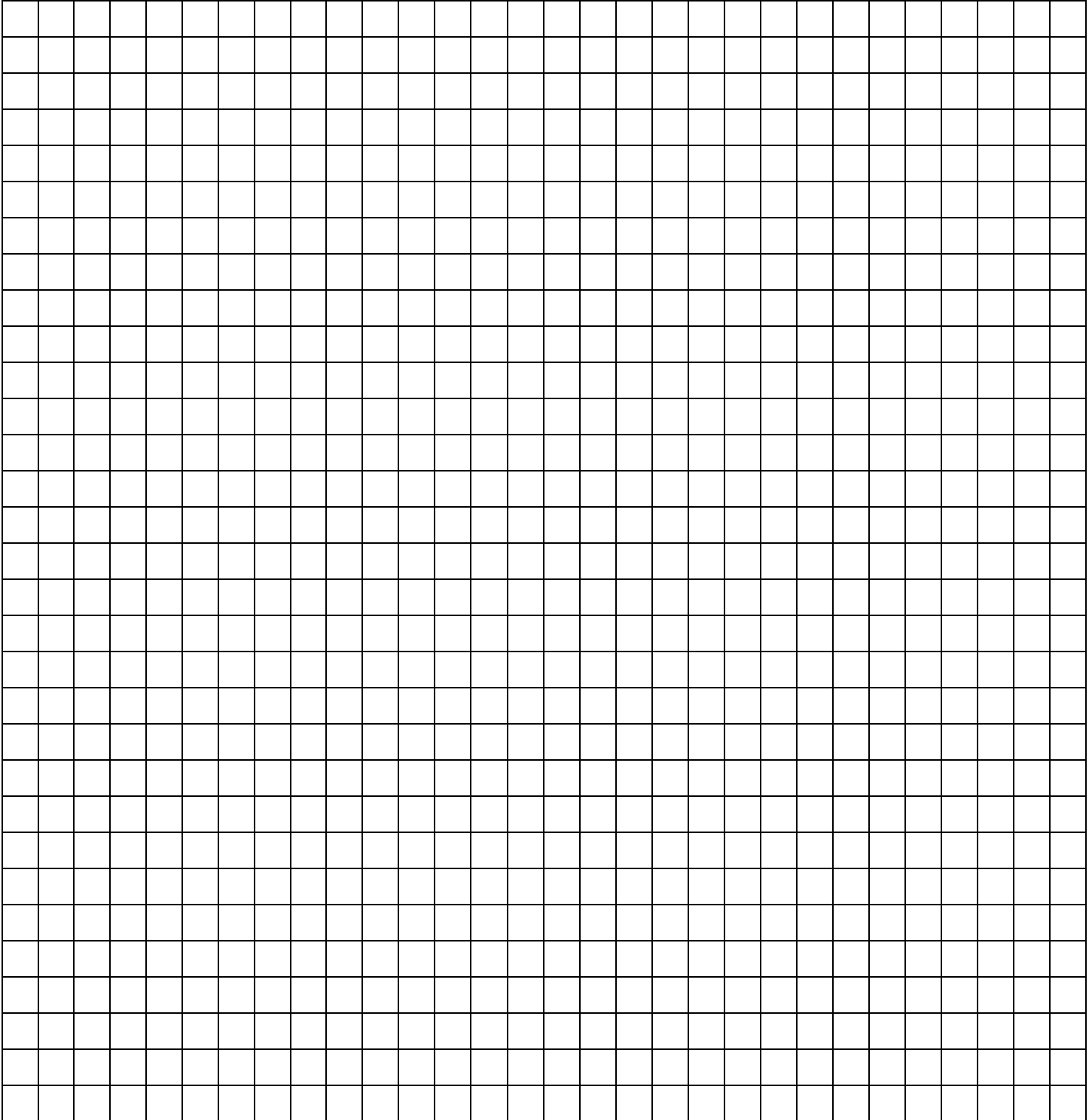

5.2d Extension Class Activity and Homework: Scale Factors and Area

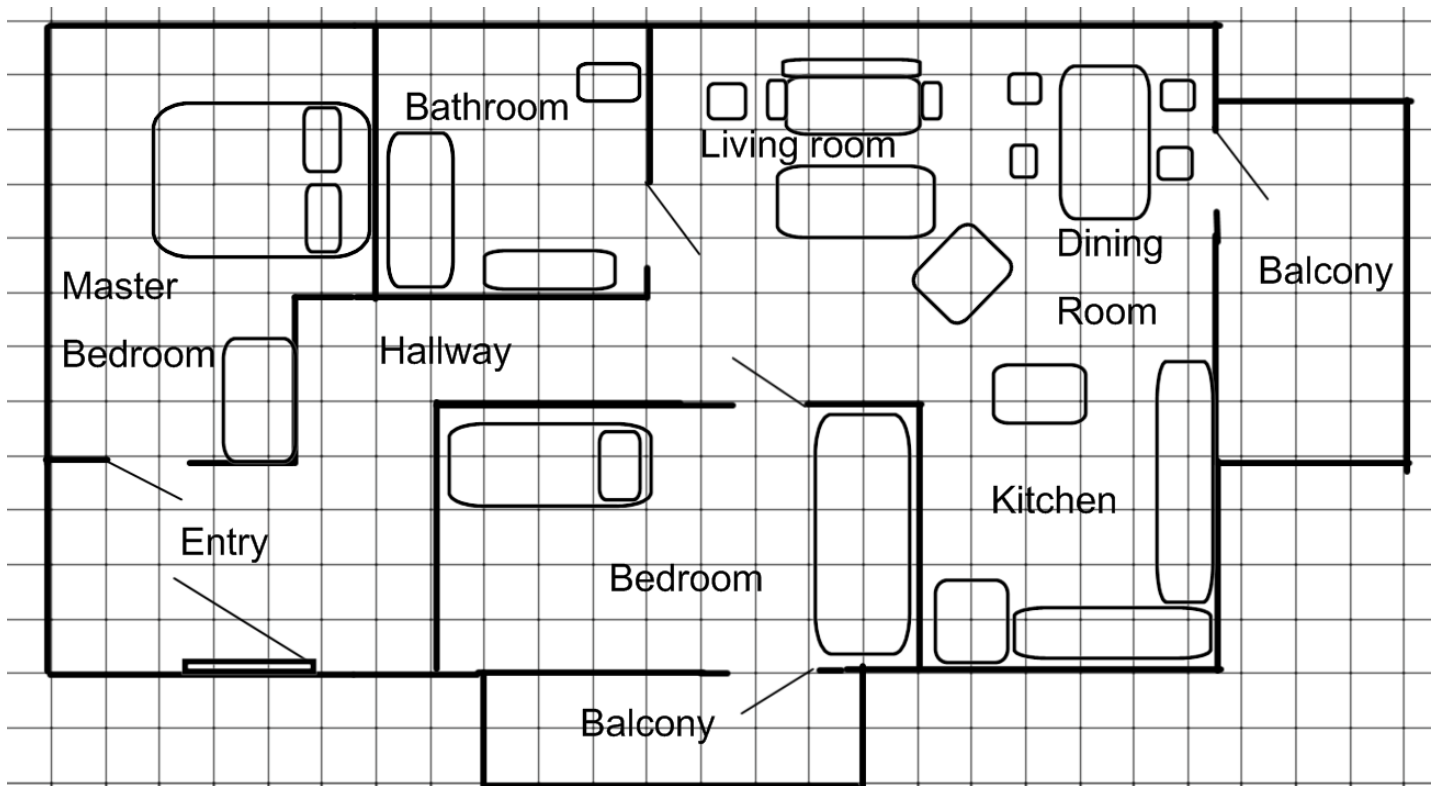

The scale drawing of a house is shown. The scale is 1 unit : 2 feet. Any wall lines that are between units are exactly halfway.

1. The balcony off the bedroom has dimensions in the drawing of 7×2 . Complete the table, including the appropriate units:

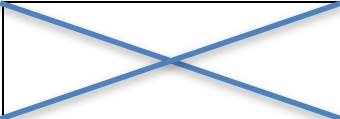
	Balcony length	Balcony width	Balcony area
			
Drawing	7 units	2 units	
Actual house			

2. What is the scale factor to get from units in the drawing to feet in the house? **1 unit : 2 feet, so the scale factor is 2—one multiplies the units by 2 to find the length in feet.**
3. What is the scale factor to get from square units in the drawing to square feet in the house?
4. If the architect includes a bench on the balcony that has dimensions 2.5×1 units, what are the dimensions of the bench in the house? **5 ft \times 2 ft**

5. Complete the table for the bathroom, including the appropriate units:

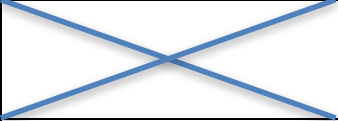
	Bathroom length	Bathroom width	Bathroom area
Drawing	5 units	5 units	25 square units
Actual house	10 feet	10 feet	100 square feet

6. What is the ratio of $\frac{\text{area in house}}{\text{area in drawing}}$? **4:1**

7. If the backyard in the drawing has an area of 150 square units, how big is the area of the actual backyard of the house?

8. If the walkway to the entryway is 6.5 units long in the drawing, how long is the walkway on the house?

9. Use the drawing to determine how wide each interior door in the house is.
3 feet

10. Approximately how long is each bed in the house?

11. By counting the number of square units in the master bedroom in the drawing, calculate the area of the master bedroom in the house. Include the area taken up by furniture.
174 square feet

12. Challenge: What is the total square footage of the house, including the balconies? Show your work, labeling the expressions for each step with what they represent in the house.

5.2d Homework: Scale Factors and Area

1. Mouse's house is very small. His living room measures 2 feet by 4 feet. Draw his living room on the grid. Label the dimensions and the area.
2. Double-Dog's living room dimensions are double Mouse's living room. Draw his living room on the grid. Label the dimensions and the area.
3. Triple-Threat-Tiger's living room is triple the dimensions of Double-Dog's. Draw Tiger's living room on the grid. Label the dimensions and the area.

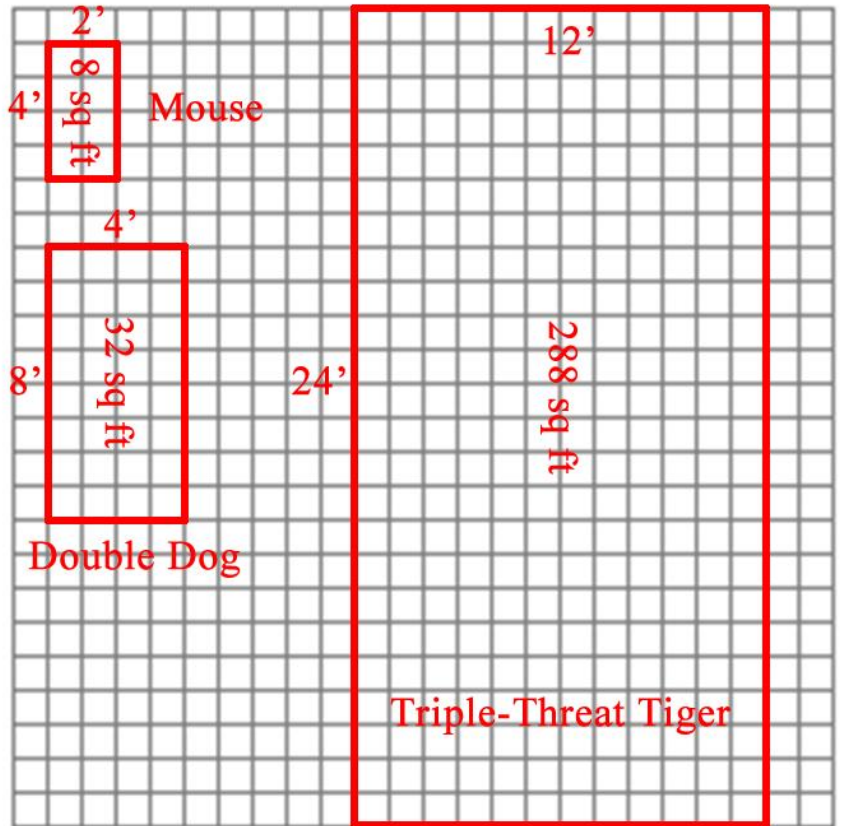

4. Fill in the table below with the dimensions and areas of the living rooms from the sketches above.

Homeowner	Living Room Dimensions (Length and Width)		Living Room Area
Mouse	2 feet	4 feet	8 sq. feet
Double-Dog	4 feet	8 feet	32 sq. feet
Triple-Threat-Tiger	12 feet	24 feet	288 sq. feet

5. Compare measurements for Mouse and Double-Dog's living rooms. Use scale factor in the comparison.
 - a. the dimensions
Mouse:Double dog = 1:2
Scale factor is for length is 2
 - b. the area
Mouse: Double dog = 1:4
Scale factor for area is 4
6. Compare measurements for Double-Dog and Triple-Threat-Tiger's living rooms. Use scale factor.
 - a. the dimensions
Double dog:Triple-Threat = 1:3
Scale factor is for length is 3
 - b. the area
Double dog:Triple-Threat = 1:9
Scale factor for area is 9
7. Compare Mouse and Triple-Threat-Tiger's living rooms. Use scale factor in the comparison.
 - a. The dimensions
Mouse :Triple-Threat = 1:6
Scale factor is for length is 6
 - b. the area
Mouse:Triple-Threat = 1:36
Scale factor for area is 36

8. Generalize a rule related to the scale factors of dimensions and area. You might use “if...., then....”

For example: “If the dimensions of an object are multiplied by _____, the area will be multiplied by _____.”

If the dimensions of an object are multiplied by x , then the area will be multiplied by x^2



9. If the area of Mouse’s **kitchen** is 12 square feet, and the dimensions of Double-Dog’s kitchen are twice as big as the dimensions of Mouse’s, what will the area of Double-Dog’s kitchen be?

48 sq. feet

10. If the dimensions of Triple-Threat-Tiger’s kitchen are three times the dimensions of Double-Dog’s, what will the area of Triple-Threat-Tiger’s kitchen be?

432 sq. feet

11. If the area of Mouse’s bathroom is 5 square feet, the dimensions of Double-Dog’s bathroom are twice Mouse’s, and Triple-Tiger’s are three times Double-Dog’s, what will the area of Triple-Threat-Tiger’s bathroom be? Is there a shortcut?

180 sq. feet. Yes, multiply the two scale factors together: $4 \times 6 = 36$

12. Ms. Herrera decided to shrink a picture so that it would fit on a page with some text. She went to the copy machine and pushed the 50% button, meaning that the **dimensions** of the paper would be **half** as big as normal.

- a. If the original dimensions of the picture were 8.5 in. X 11 in., what will be the dimensions of the new picture?
4.25 in. x 5.5 in.
- b. Draw the original and new picture on the grid. Label the dimensions.
- c. If you know the area of the original picture, how might you figure out the area of the smaller picture (besides multiplying length and width)?

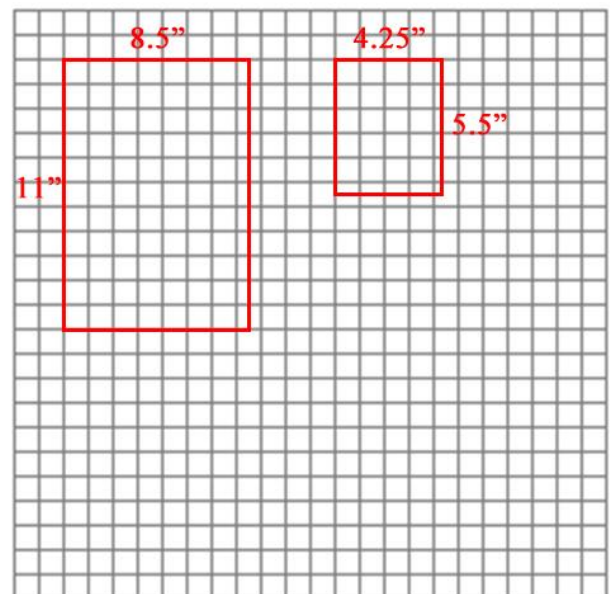

$(\frac{1}{2})^2 = \frac{1}{4}$, multiply the area by $\frac{1}{4}$

13. Let’s say that Mouse, Double-Dog and Triple-Threat-Tiger all have swimming pools. What would you predict about the scale factor of the volume as related to double or triple dimensions? Prove or adjust your prediction—say that Mouse has a pool which is 1 foot deep and 2 feet by 3 feet.



You would cube the scale factor of the lengths.

5.2e Self-Assessment: Section 5.2

Consider the following skills/concepts. Rate your comfort level with each skill/concept by checking the box that best describes your progress in mastering each skill/concept. Sample problems can be found on the following page.

Skill/Concept	Beginning Understanding	Developing Skill and Understanding	Practical Skill and Understanding	Deep Understanding, Skill Mastery
1. Draw a scaled version of a triangle, other polygon, or other object given lengths.	I can't draw a scaled version of a triangle, other polygon, or other object.	I can draw a scaled version of a triangle, other polygon, or other object if given some assistance.	I can draw a scaled version of a triangle, other polygon, or other object given the lengths without assistance.	I can draw a scaled version of a triangle, other polygon, or other object given the lengths without assistance. I can explain the method used to draw the scaled version.
2. Find a measure of a scaled object given the scale factor and measure from the original.	I struggle to find a measure of a scaled object given the scale factor and measure from the original.	I can find measures of scaled objects given the scale factor and measure from the original if the scale factor is a whole number.	I can find measures of scaled objects given the scale factor and measure from the original.	I can find measures of scaled objects given the scale factor and measure from the original. I can explain the logic of the method used to find the new measures.
3. Find the scale factor between two objects that are the same shape but different sizes/proportional.	I struggle to find the scale factor between two objects.	I can find the scale factor between two objects if the scale factor is a whole number and/or I sometimes get confused between proportion and scale factor.	I can find the scale factor between two objects and know how it's related to proportionality.	I can find the scale factor between two objects. I can explain the logic of the method used to find the scale factor and how scale factor is related to proportionality.
4. Use proportional reasoning in explaining and finding missing sides of objects that are the same shape but different sizes.	I struggle to know how to find a missing side using proportional reasoning.	I can usually set up a proportion to find missing sides, but I sometimes mess up and/or I confuse proportionality and scale factor sometime.	I can find missing sides using proportional reasoning either from a proportional relationship or from a scale factor.	I can find a missing sides, and I can explain the relationship between two objects that are the same shape, different size using proportional reasoning and extend that explanation to scale factor.
5. Find the scale factors for perimeter or area for proportional objects.	I struggle to understand how changes in length affect the scale factor for perimeter and/or area of two objects of the same shape.	I know how changes in length affect the scale factor for perimeter and area of two objects of the same shape. I can also usually find the scale factors or new perimeters and areas.	I know how changes in length affect the scale factor for perimeter and area of two objects of the same shape. I can also always find the scale factors or new perimeters and areas.	I know how changes in length affect the scale factor for perimeter and area of two objects of the same shape. I can also always find the scale factors or new perimeters and areas and explain why the procedure works.

Sample Problems for Section 5.2

1. Draw a scaled version of the following polygons given the scale factor.

a. Scale Factor: 2

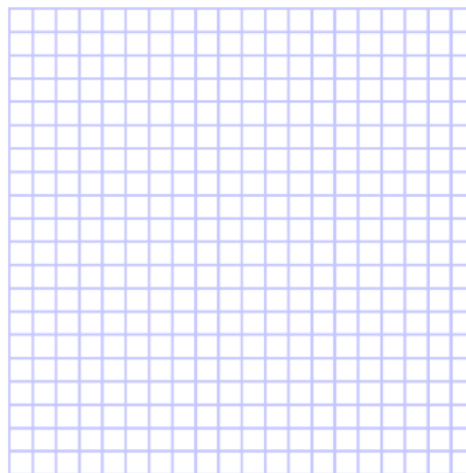
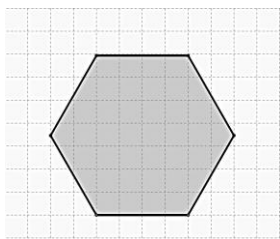

b. Scale Factor: $\frac{1}{2}$

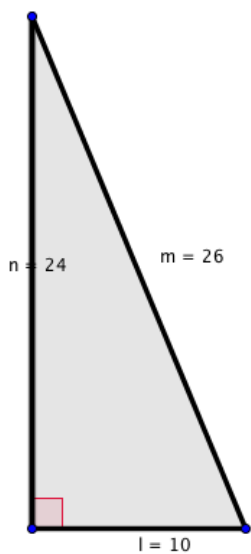

2. Find the missing measurement in each problem.

a. The scale factor $\triangle ABC$ to $\triangle DEF$ is 3. If \overline{BC} is 3, what is the length of \overline{EF} ?

b. The scale factor $\triangle GEL$ to $\triangle HOP$ is $\frac{3}{5}$. If \overline{OP} is 30, what is the length of \overline{EL} ?

3. In each of the following, what is the scale factor that takes $\triangle ABC$ to $\triangle XYZ$?

a.

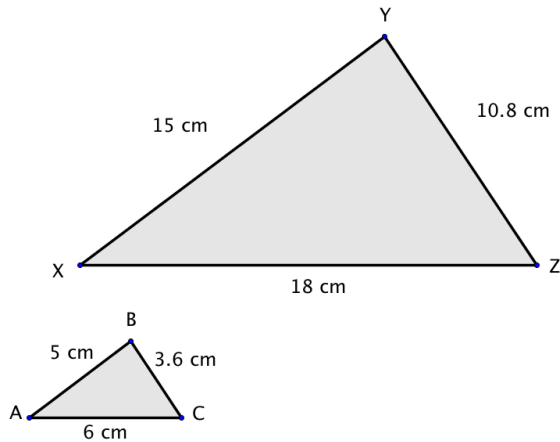

b.

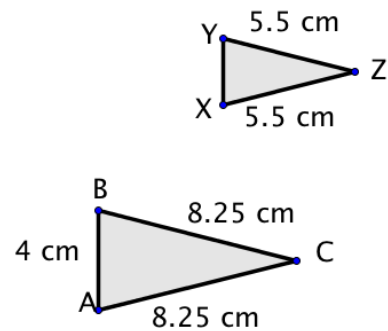

4. Answer each of the following questions using proportional reasoning.

a. Becky is drawing a scale model of her neighborhood. She uses a scale of 1 in = 200 feet. If her block is 1000 feet long, what will be the length of the block on her scale model?

b. Carlos is reading a map of his town. The scale says 1 in = 4 miles. The distance from his house to the school is $\frac{3}{8}$ in. on the map. If Carlos wants to walk to school from his house, how far will he have to walk?

5. The dimensions of Romina's rectangular garden are 2 feet by 3 feet. The dimensions of Santiago's garden are all quadrupled.

- Find the perimeter and area of each garden.
- Find the scale factor between the perimeters of each garden.
- Find the scale factor between the areas of each garden.
- In general, how are the scale factors of perimeters and areas of scaled objects related?

Section 5.3: Solving Problems with Circles

Section Overview: In this section circumference and area of a circle will be explored from the perspective of scaling. Students will start by measuring the diameter and circumference of various circles and noting that the ratio of the circumference to the radius is constant (2π). This should lead to discussions about all circles being scaled versions of each other. Next students will “develop” an algorithm for finding the area of a circle using strategies used throughout mathematical history. In these explorations, students should discuss two ideas: 1) cutting up a figure and rearranging the pieces so as to preserve area, and 2) creating a rectangle is a convenient way to find area. Students will connect the formula for finding the area of a circle (πr^2) to finding the area of a rectangle/parallelogram where the base is $\frac{1}{2}$ the circumference of the circle and the height is the radius ($A = Cr/2$.)

Students end the section by applying what they have learned to problem situations. In Chapter 6, students will use ideas of how circumference and area are connected to write equations to solve problems, but in this section, students should solve problems using informal strategies to solidify their understanding.

Concepts and Skills to be Mastered (from standards)

Geometry Standard 4: Know the formulas for the area and circumference of a circle and use them to solve problems; give an informal derivation of the relationship between the circumference and area of a circle.

Geometry Standard 6: Solve real-world and mathematical problems involving area, volume and surface area of two- and three-dimensional objects composed of triangles, quadrilaterals, polygons, cubes, and right prisms. 7.G.6

1. Explain the relationship between diameter of a circle and its circumference and area.
2. Explain the algorithm for finding circumference or area of a circle.
3. Find the circumference or area of any circle given the diameter or radius; or given circumference or area determine the diameter or radius.

5.3a Class Activity: How Many Diameters Does it Take to Wrap Around a Circle?

1. Create *one* circle using either a) manual construction: a compass, tracing the base of a cylindrical object, or using a string compass, OR b) technology: GeoGebra, etc. (technology will allow for far more accurate measurement). Then, measure the *circumference* and diameter of the circle; collect measurements from five other students to fill in the table below.

Measurement of the diameter in _____ units	Measurement of the circumference in _____ units (must be the same units as the diameter)	Ratio of circumference : diameter (C/d), as a decimal rounded to the nearest hundredth. Note: C represents <i>circumference</i> and d represents <i>diameter</i> .
		3.14
		3.14
		3.14
		3.14
		3.14

2. What do you notice about the values in the third column?

They are all about 3.14. You will need to *Attend to Precision*. Introduce π . Explain that it represents the ratio of the circumference to the diameter of a circle. Students will study irrational numbers in 8th grade.

3. If you made a huge circle the size of a city and measured the diameter and circumference, would the ratio of circumference to diameter (C/d) be consistent with the other ratios in the third column of the table? Justify your answer using what you learned from the previous section.

All circles are scale drawings of each other so the ratio of circumference to diameter is always the same.

4. If you know the diameter of a circle is 5 inches, what is the approximate measure of the circumference? Justify your answer. 15.7 inches.

5. Write and justify a formula for circumference, in terms of the diameter.

$C = 3.14d$ extend this to $C = \pi d$ or $C = \pi(2r) = 2\pi r$

6. Write and justify a formula for the circumference, in terms of the radius.

$C = 3.14(2r)$ or $C = 6.28r$ or $C = 2\pi r$. You are pushing for students to look at the *structure and repeated reasoning*. In other words, all circles have the same shape. The ratio of their circumference to diameter is always the same so we can write the circumference as the diameter and a factor (pi.) We can repeat this reasoning with any circle. Note we are using the term “factor.” All circles are scaled versions of each other.

7. For each of the three circles below, calculate the circumference of the circle. Express your answer both in terms of π , and also as an approximation to the nearest tenth. *Please note: drawing is not to scale.*

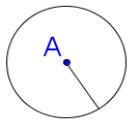

radius = 0.5 cm
circumference = C
Solve for C.

$C = 3.14 \text{ cm}$
 $C = \pi \text{ cm}$

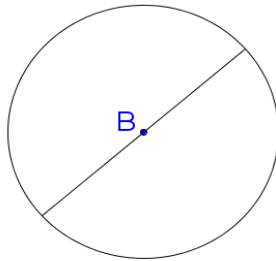

Diameter = 2.5 cm
circumference = C
Solve for C.

$C = 7.85 \text{ cm}$
 $C = 2.5\pi \text{ cm}$

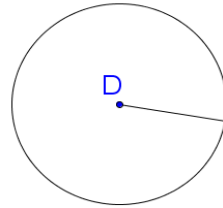

radius = 3 units
circumference = C
Solve for C.

$C = 18.84 \text{ units}$
 $C = 6\pi \text{ units}$

Discuss “exact” v “approximate.” In the problems above, the second answer, written in terms of pi, is the exact answer. The first answer is an approximate.

8. If the circumference of a circle is 8π (approximately 25.1) inches, which of the following is true? Rewrite false statements to make them true.

- The ratio of Circumference: Diameter is 8. **False: the ratio is $8\pi/8$ or π**
- The radius of the circle is $\frac{1}{2}$ the circumference. **False: the radius is $\frac{1}{2}$ the diameter.**
- The diameter of the circle is twice the radius. **True**
- The radius of the circle is 8 inches. **False: the radius is 4 inches.**
- The diameter of the circle is 8 inches. **True**

9. The circumference of 5 objects is given. Calculate the diameter of each object, to the nearest tenth of a unit.



Circumference of bike wheel

76.9"

$$d = 24.5''$$

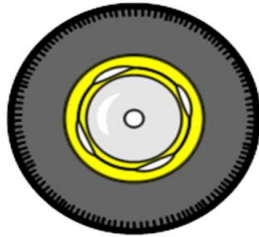

Circumference of car tire

78.1"

$$d = 24.9''$$



Circumference of lid

11"

$$d = 3.5''$$



Circumference of top of garbage can

50"

$$d = 15.9''$$

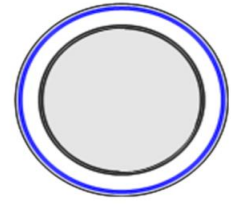

Circumference of plate

31"

$$d = 9.9''$$

10. The diameter or radius of 5 objects is given. Calculate the circumference of each object, to the nearest tenth of a unit.

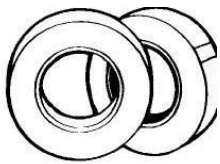

Diameter of masking tape

5"

$$C = 15.7''$$

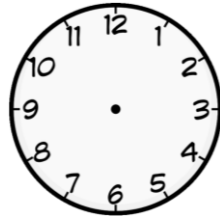

Radius of clock face

11"

$$C = 69.08''$$



Diameter of ring

2.5 cm

$$C = 7.85 \text{ cm}$$

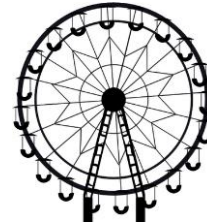

Diameter of Ferris wheel

50'

$$C = 157'$$



Radius of steering wheel

9"

$$C = 56.62''$$

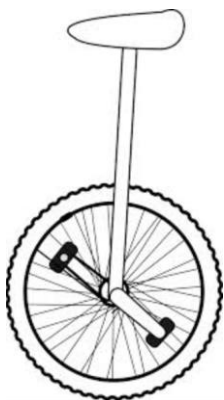

11. When a unicyclist pedals once, the wheel makes one full revolution, and the unicycle moves forward the same distance along the ground as the distance around the edge of the wheel. If Daniel is riding a unicycle with a diameter of 20 inches, how many times will he have to pedal to cover a distance of 50 feet? Show all your work.

$$50 \text{ feet} = 600 \text{ inches.}$$

$$C \text{ of unicycle} = 20\pi \text{ in.} = 62.8 \text{ in.}$$

$$600 \div 62.8 = 9.55 \text{ revolutions.}$$

He will have to pedal 9.55 times.

Spiral Review

1. Factor the following expressions.

$4x - 10 \quad 2(2x - 5)$

$21x + 35 \quad 7(3x + 5)$

$5.4t - 2.7 \quad .9(6t - 3)$

2. Use a model to represent $-7 + 14 = 7$

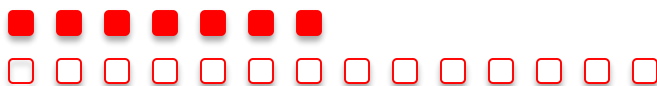

3. Find 30% of 240 without a calculator. 72

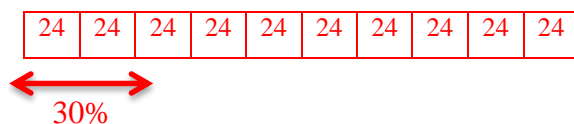

4. Without using a calculator, determine which fraction is bigger in each pair. Justify your answer with a picture *and* words.

a. $\frac{21}{25}$ or $\frac{3}{5}$

b. $\frac{6}{11}$ or $\frac{8}{14}$

5. Milly bought two sweaters for \$30 and three pair of pants for \$25. She had a 20% off coupon for her entire purchase. Model or write an expression for the amount of money Millie spent. 108

$$[2(30) + 3(25)] = 135$$

$$135 (.20) = 27$$

$$135 - 27 = 108$$

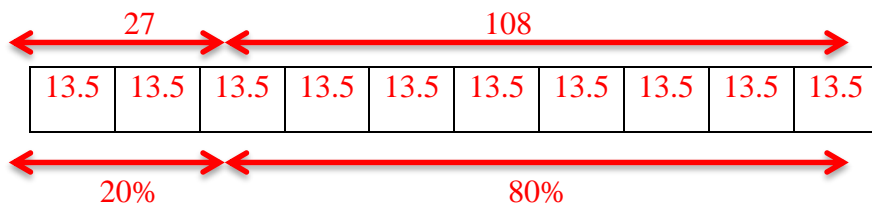

5.3a Homework: How Many Diameters Does it Take to Wrap Around a Circle?

1. Identify 5 circular objects around the house (canned foods, door knobs, cups, etc.). Find the measure of each object's diameter and then calculate its circumference. Put your results in the table below:

Description of item	Diameter (measured)	Circumference (calculated)	Ratio of $C : d$ (calculated) to the nearest hundredth

2. What is the exact ratio of the circumference to the diameter of every circle?

π

3. If the radius of a circle is 18 miles,
- What is the measure of the diameter?
 - What is the measure of the circumference, exactly in terms of pi?
 - What is the approximate measure of the circumference, to the nearest tenth of a mile?
4. For each of the three circles below, calculate the circumference. Express your answer both in terms of pi, and also as an approximation to the nearest tenth.

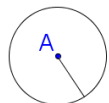

radius = 1.5 cm
circumference = C
Solve for C.

$C = 3\pi \text{ cm}$
 $C = 9.4 \text{ cm}$

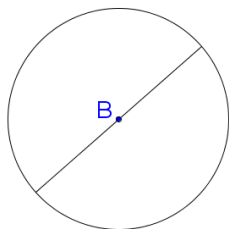

Diameter = 5 cm
circumference = C
Solve for C.

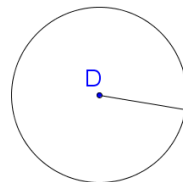

radius = 9 units
circumference = C
Solve for C.

5. The decimal for π starts with 3.141592653589... Which fraction is closest to π ? (Note: there is no fraction that is *exactly* equal to π .)

a) $3\frac{1}{4}$	b) $3\frac{1}{5}$	c) $3\frac{1}{7}$	d) $3\frac{1}{6}$	e) $3\frac{1}{8}$
-------------------	-------------------	-------------------	-------------------	-------------------

6. If the circumference of a circle is 20π feet, which of the following statements are true? Rewrite false statements to make them true.
- The circumference of the circle is exactly 62.8 feet. **False: circumference is approximately 62.8 ft**
 - The diameter of the circle is 20 feet.
 - The radius of the circle is 20 feet. **False: the radius is 10 feet**
 - The ratio of circumference : diameter of the circle is π .
 - The radius of the circle is twice the diameter.

7. The circumference of 5 objects is given. Calculate the diameter of each object, to the nearest tenth of a unit.



Circumference
of bottom of
cupcake

6.5"

$d = 2.1$ "



Circumference
of top of mug

13"



Circumference
of wheel

314 cm



Circumference
of top of water
pail

100 cm



Circumference
of earth

24,901 miles

$d = 7,930.3$ miles

8. The diameter or radius of 5 objects is given. Calculate the circumference of each object, to the nearest tenth of a unit.

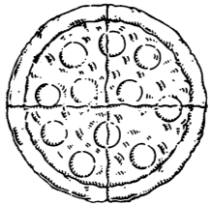

Diameter
of pizza
16"



Diameter of
rim of a drum
24"



Radius of
table top
2'



Diameter of
coin
5 cm

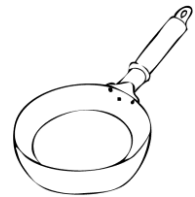

Radius of
frying pan
5.5"

$$C = 50.2''$$

$$C = 34.5''$$

9. Three tennis balls are stacked and then tightly packed into a cylindrical can. Which is greater: the height of the can, or the circumference of the top of the can? Justify your answer.

10. Calculate the radius for each circle whose circumference is given in the table (the first entry is done for you). Then graph the values on a coordinate plane, with the radius on the x axis and the approximate circumference on the y axis.

Radius of circle	4 units	5 units						
Circumference of circle	8π un ≈ 25 un	$10\pi \approx 31$ un	2π un ≈ 6 un	16π un ≈ 50 un	6π un ≈ 19 un	18π un ≈ 57 un	4π un ≈ 13 un	12π un ≈ 38 un

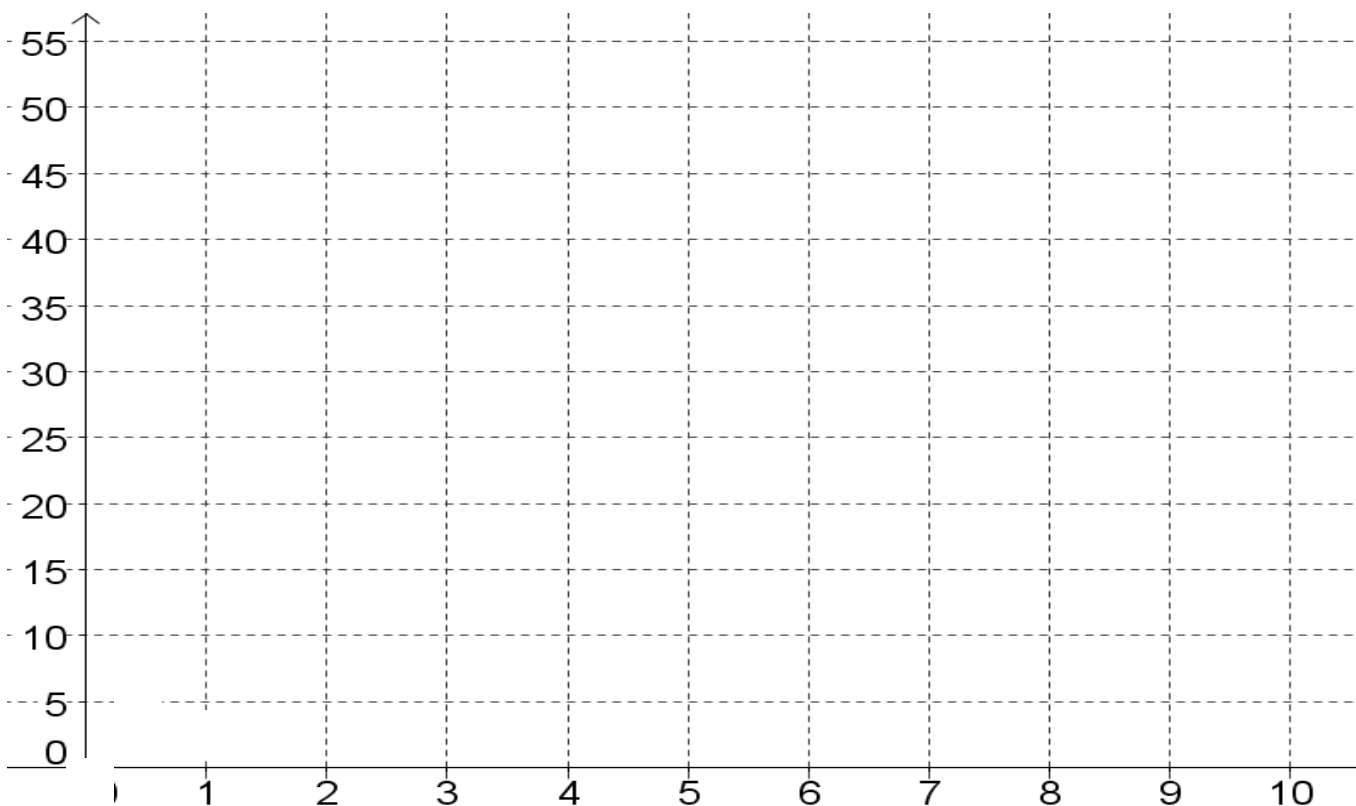

11. Is the radius of a circle proportional to the circumference of the circle? Justify your answer.

Yes, the graph is a straight line.

5.3b Classwork: Area of a Circle

Activity: Circle Area

History: Methods for computing the area of simple polygons were known to ancient civilizations like the Egyptians, Babylonians and Hindus from very early times in Mathematics. But computing the area of circular regions posed a challenge. Archimedes (287 BC – 212 BC) wrote about using a method of approximating the area of a circle with polygons. Below, you will try some of the methods he explored for finding the area of a circle of diameter 6 units.

a) Estimate the area of the circle by counting the number of square units in the circle.

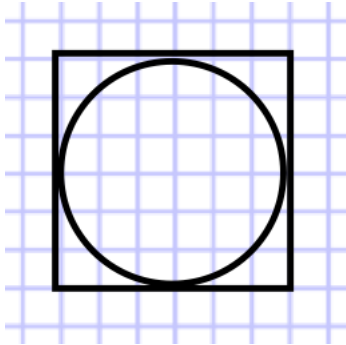

Estimated area = _____

b) Estimate the area of the circle by averaging the inscribed and circumscribed squares.

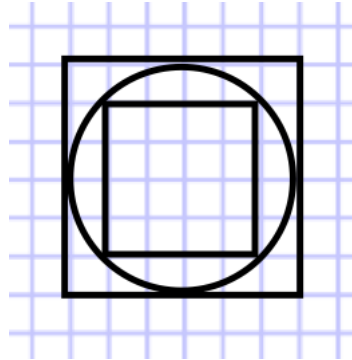

Estimated area = _____

c) In the figure below on the left, the large square circumscribing the circle is divided into four smaller squares. Let's call the four smaller squares "radius squares." The four radius squares are lined up below on the right. Estimate the number of squares units (grid squares) there are in the circle and then transfer them to the four radius squares below.

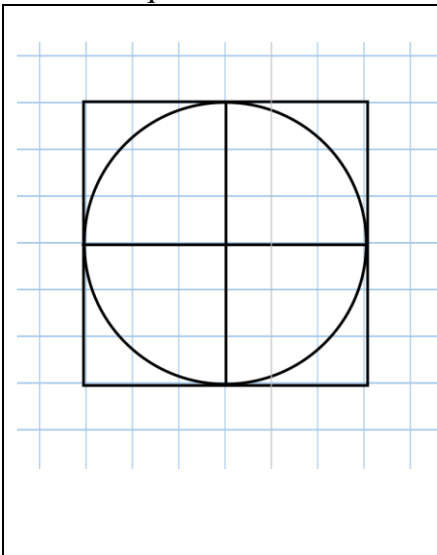

The idea here is to fill in the area of a little over 3 radius squares. Students should see that a $\frac{1}{4}$ portion of the circle is a bit more than 7 square units, so the whole area of the circle is a little over 28 square units. The area of the large rectangle is 36 sq un., thus the area of the circle is about $\frac{28}{36}$ of the large rectangle. Student might also say it's a bit more than $\frac{3}{4}$ the area of the large square or about 3 of the smaller radius squares.

How many radius squares cover the same area as the circle? _____

Johannes Kepler (1571-1630) tried a different approach: he suggested dividing the circle into “isosceles triangles” and then restructuring them into a parallelogram. Refer to the Mathematical Foundation for more information about this approach.

Cut the circle into eighths. Then fit and paste the eighths into a long line (turn the pie pieces opposite ways) to create a “parallelogram.”

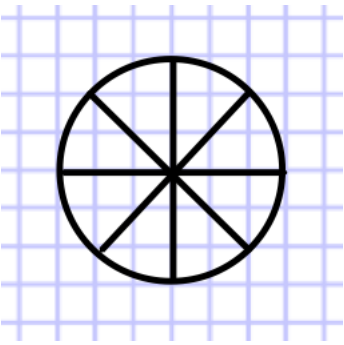
	<p>Students should end up with a figure like the one on the next page. Remind them that the area of a parallelogram is height times base. Discuss what the height and the base are relative to the original circle. This activity is extended in the next activity.</p>
---	---

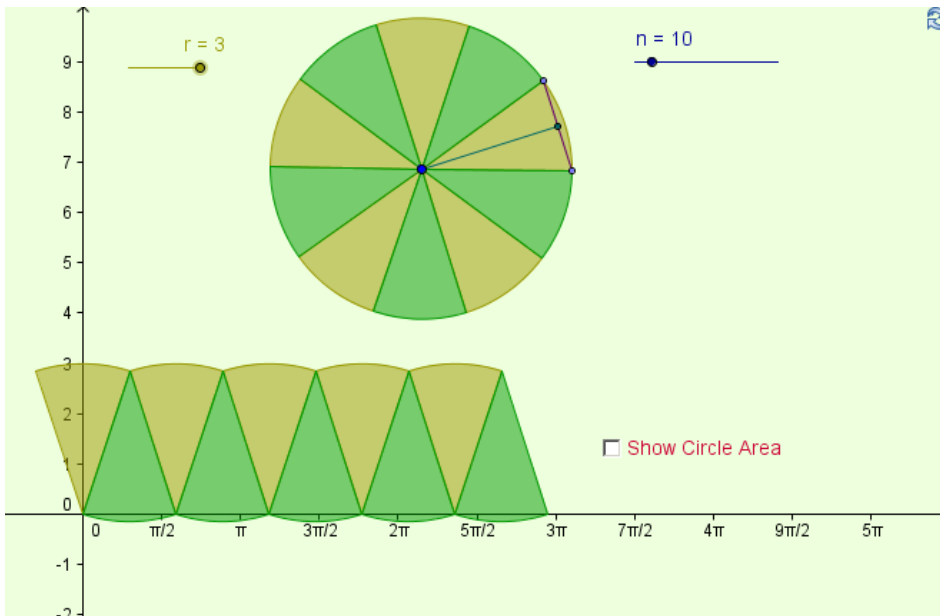

The figure to the left shows the same circle of radius 3 as the previous example, but this time cut into 10 wedges. How will this parallelogram compare to the one created with 8 wedges above? **The edges will be smoother. More of a parallelogram. There will be less approximation because the “gap” will be smaller.**

Will the area created by reorganizing the pieces be the same or different than the original circle? **Explain. All the areas will be the same.**

In the next diagram, the same circle of radius 3, but this time it’s cut into 50 wedges. Again it is packed together into a parallelogram.

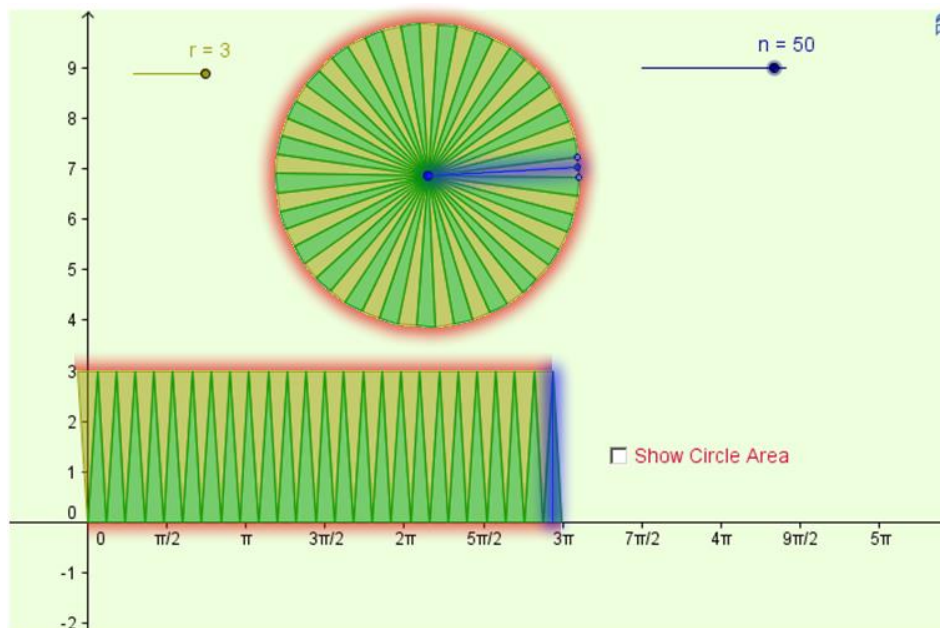

Highlight the circumference of the circle. Then highlight where the circumference is found in the new diagram. Explain why the base of the “parallelogram” is half the circumference of the circle.

Half the circumference is on the top of the “rectangle,” the other half is on the bottom.

Highlight the radius of the circle in a different color. Then highlight where the radius is found in the new diagram. Explain why the height of the “parallelogram” is the same as the radius. **It cuts right down the middle of one of the slices.**

Use the figure and what you know about the area of a rectangle to write an expression for the area of the circle.

$$A = \pi r^2$$

1. Estimate the area of the circle in square units by counting.

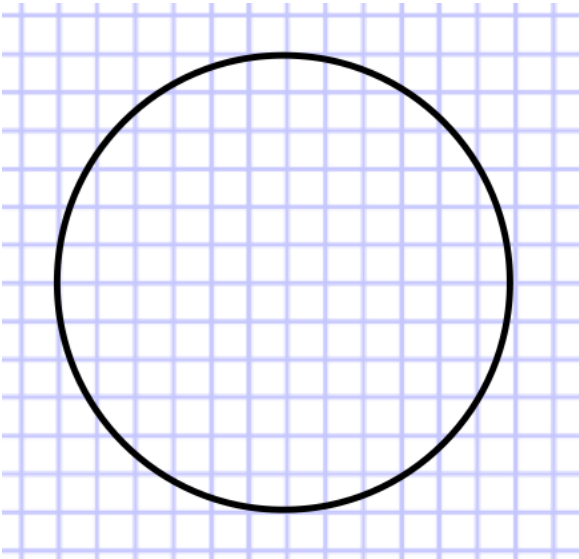

2. Use the formula for the area of a circle to calculate the exact area of the circle above, in terms of π .

36π square units

3. Calculate the area for #2 to the nearest square unit. How accurate was your estimate in #1?

113 square units

4. Calculate the area of each circle. Express your answer both exactly (in terms of π) and approximately, to the nearest tenth of a unit.

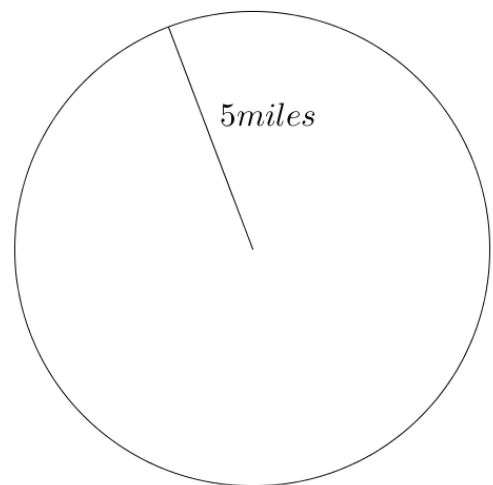
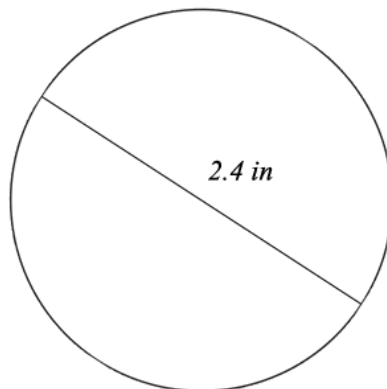
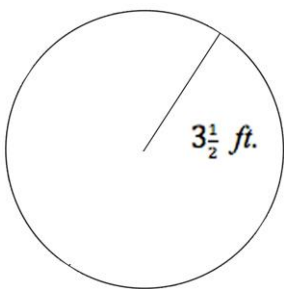

$A = 12.25\pi$ sq. ft.
 $A = 38.5$ sq. ft.

5. A certain earthquake was felt by everyone within 50 kilometers of the epicenter in every direction.
- Draw a diagram of the situation.

- What is the area that felt the earthquake?

2500π or 7,825 square kilometers

6. There is one circle that has the same numeric value for its circumference and its area (though the units are different.) Use any strategy to find it. Hint: the radius is a whole number.

A circle with a radius of 2.

Earlier in this section, we noted that the ratio $C:d$ (or $C:2r$) is π for all circles. We then noticed that the area for all circles is $Cr/2$ (e.g. $2\pi r \times r/2$ or πr^2). Thus the ratio of area of a circle to r^2 ($A:r^2$) is also π . $2r = r^2$ only for $r = 2$ so $A = C$ only for $r = 2$. The fact that the ratios of both $C:d$ (or $C:2r$) and $A:r^2$ are the same constant, π , is very interesting (and important). A more thorough development of this concept is offered in the Mathematical Foundation. The idea that the circumferences of two circles are related by the scale factor taking one circle's radius to the other should connect to the notion that the perimeter of scaled polygons are related to the scale factor for the sides (as discussed earlier in this chapter). In the case of area, for both the circle and polygons, the area is proportional to the square of the linear scale factor.

7. Explain the difference in the units for circumference and area for the circle in #6. **Circumference is a length, so it is in just units. Area is in square units.**

8. Draw a diagram to solve: A circle with radius 3 centimeters is enlarged so its radius is now 6 centimeters.

- By what scale factor did the circumference increase? Show your work or justify your answer.

2

- By what scale factor did the area increase? Show your work or justify your answer.

4

- Explain why this makes sense, using what you know about scale factor.

The scale factor of the area is always the square of the scale factor of the lengths.

9. How many circles of radius 3'' can you fit in a circle with radius 12'' (if you could cut up the smaller circles to tightly pack them into the larger circle with no gaps)? See the image below. Justify your answer.

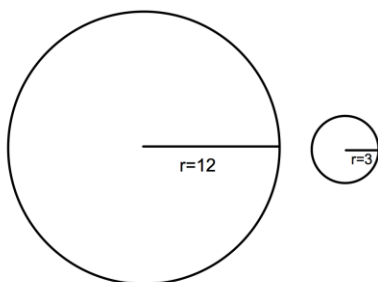

16, because the scale factor of the radii is 4, so the scale factor of the area is going to be 4^2 or 16. Another way to think about it: the area of the larger circle is 144π , while the area of the smaller circle is 9π . Thus, 16 of the smaller circles make up the larger.

10. Calculate the radius for each circle whose area is given in the table (the first entry is done for you). Then graph the values on a coordinate plane, with the radius on the x axis and the approximate area on the y axis.

Radius of circle	6 units	4 units	9 units	5 units	3 units	8 units	7 units	2 units
Area of circle	$36\pi \text{ un}^2$ $\approx 113 \text{ un}^2$	$16\pi \approx 50 \text{ un}^2$	$81\pi \text{ un}^2$ $\approx 254 \text{ un}^2$	$25\pi \text{ un}^2$ $\approx 79 \text{ un}^2$	$9\pi \text{ un}^2$ $\approx 28 \text{ un}^2$	$64\pi \text{ un}^2$ $\approx 201 \text{ un}^2$	$49\pi \text{ un}^2$ $\approx 154 \text{ un}^2$	$4\pi \text{ un}^2$ $\approx 12 \text{ un}^2$

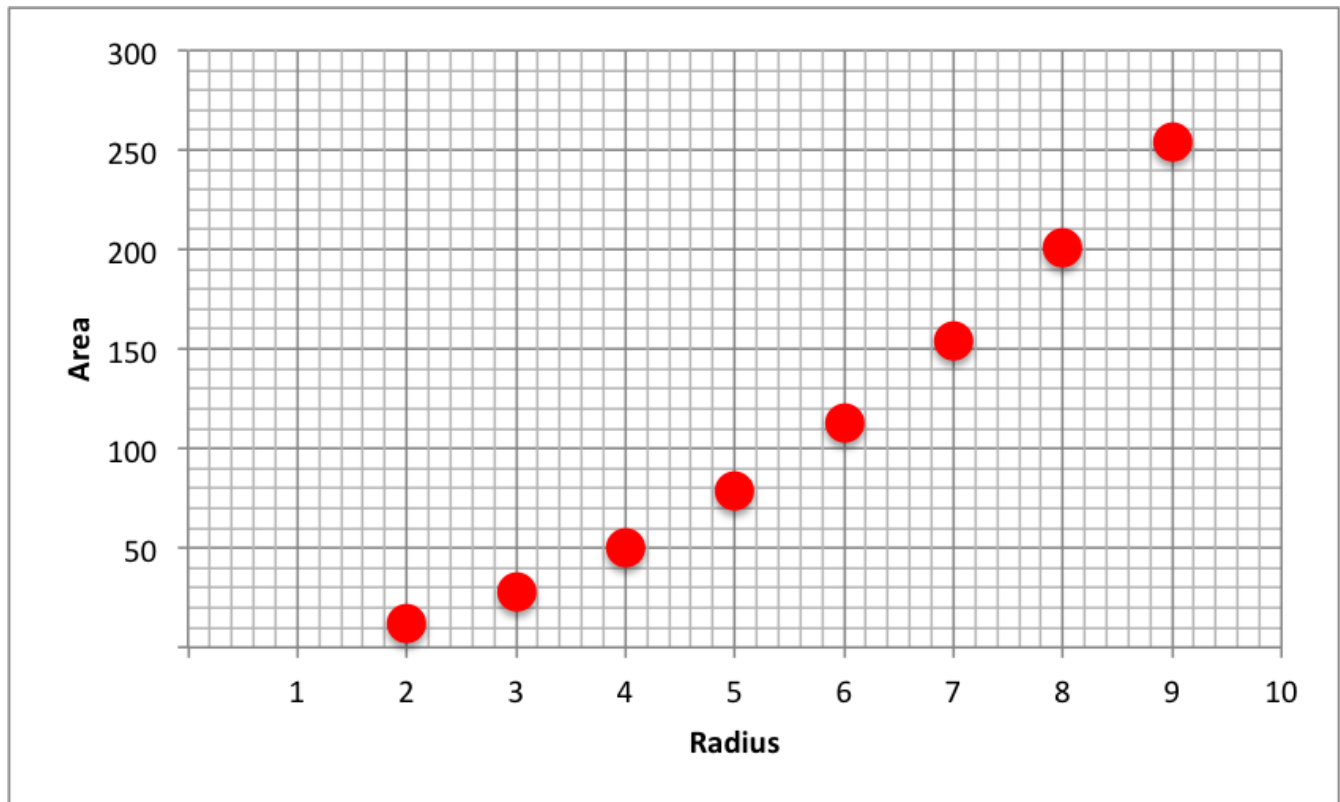

11. Is the radius of a circle proportional to the area of the circle? Justify your answer.

No, the graph is not a straight line. This should start a good conversation about rates of change that are one dimensional (perimeter) versus those that are two dimensional (area.)

Connect this exercise with 5.3a Homework #10.

12. The area of 5 objects is given. Calculate the radius of each object's surface, to the nearest hundredth of a unit.



Area of a smiley face
3.14 in²



Area of the base of a plant pot
50.24 in²
 $r = 4''$



Area of a target
153.86 in²

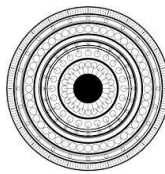

Area of circular tile pattern
78.5 ft²

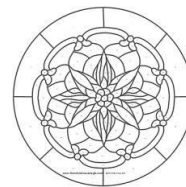

Area of glass in round window
12.56 ft²

Spiral Review

1. $7z + 1 = 15$ $z = 2$

2. $-15 = 1.2m + 2.4$ $m = -14.5$

3. Show two ways one might simplify: $5(3 + 4)$ $15 + 20 = 35$ or $5(7) = 35$

4. There are a total of 214 cars and trucks on a lot. If there are four more than twice the number of trucks than cars, how many cars and trucks are on the lot?

$$\begin{array}{rcl} (2t + 4) + t & = & 214 \\ 3t & = & 210 \\ t & = & 70 \end{array} \quad \begin{array}{r} \text{trucks} = 70 \\ \text{cars} = 144 \end{array}$$

5. $-1 \times -4 \times -7$ -28

5.3b Homework: Area of a Circle

1. Estimate the area of the circle in square units by counting.

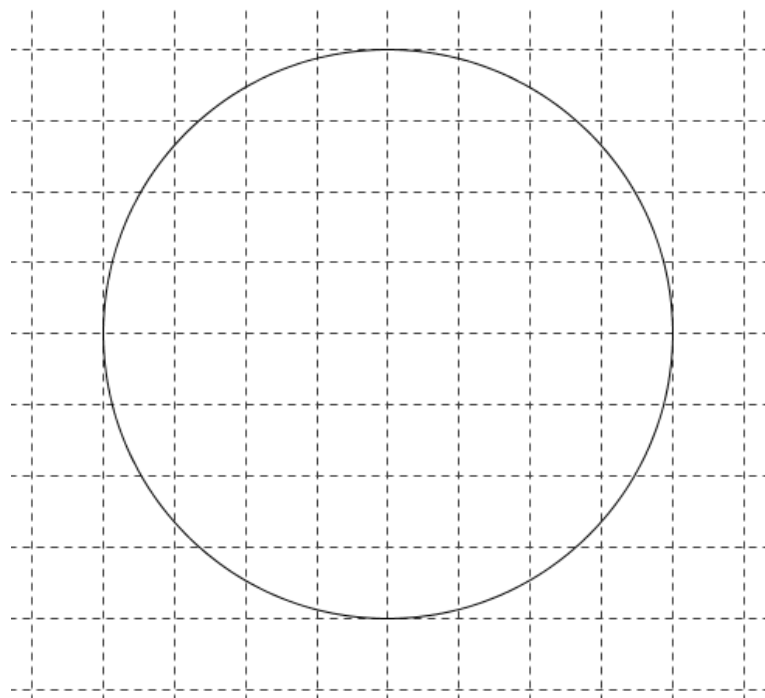

2. Use the formula for the area of a circle to calculate the exact area of the circle above, in terms of pi.
3. Calculate an approximation for the area expression from #2, to the nearest square unit. How accurate was your estimate in #1?
4. Calculate the area of each circle. Express your answer both exactly (in terms of pi) and approximately, to the nearest tenth of a unit.

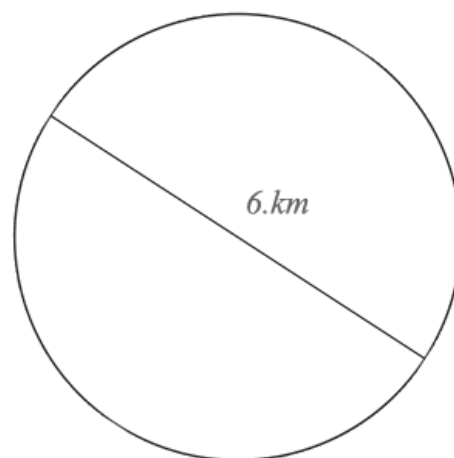
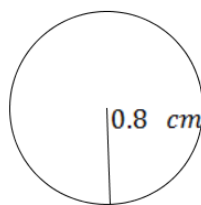
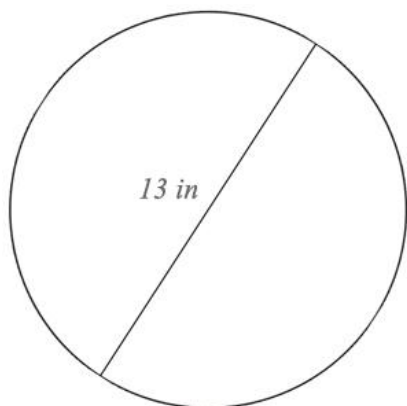

$$A = 42.25\pi \text{ sq. in.}$$

$$A = 132.7 \text{ sq. in.}$$

5. The strongest winds in Hurricane Katrina extended 30 miles in all directions from the center of the hurricane.
- Draw a diagram of the situation.

- What is the area that felt the strongest winds?

900π or 2827 sq. mi.

6. By calculating the areas of the square and the circle in the diagram, determine how many times larger in area the circle is than the square.

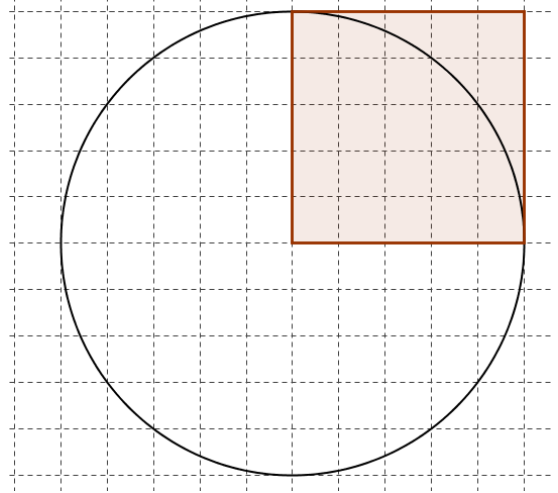

7. Draw a diagram to solve: A circle with radius 8 centimeters is enlarged so its radius is now 24 centimeters.
- By what scale factor did the circumference increase? Show your work or justify your answer.
 - By what scale factor did the area increase? Show your work or justify your answer.
 - Explain why this makes sense, using what you know about scale factor.

8. How many circles of radius 1" could fit in a circle with radius 5" (if you could rearrange the area of the circles of radius 1 in such a way that you completely fill in the circle of radius 5)? Justify your answer.
9. The area of 5 objects is given. Calculate the radius of each object's surface, to the nearest hundredth of a unit.



Area of a glass in a porthole
3.14 ft²

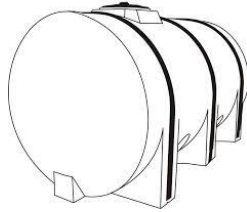

Area of side of a water tank
153.86 ft²

$$r = 7'$$

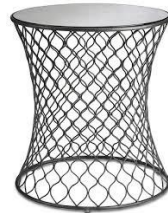

Area of wicker table top
28.26 ft²



Area of base of trash can
12.56 ft²



Area of round area rug
153.86 ft²

5.3c Self-Assessment: Section 5.3

Consider the following skills/concepts. Rate your comfort level with each skill/concept by checking the box that best describes your progress in mastering each skill/concept. Sample problems can be found on the following page.

Skill/Concept	Beginning Understanding	Developing Skill and Understanding	Practical Skill and Understanding	Deep Understanding, Skill Mastery
1. Explain the relationship between diameter of a circle and its circumference and area.	I struggle to understand the relationship between diameter of a circle and its circumference or area.	I know there is a relationship between diameter of a circle and its circumference and area, but I have difficulty explaining it.	I can explain the relationship between diameter of a circle and its circumference and area.	I can explain the relationship between diameter of a circle and its circumference and area. Additionally, I can also apply my understanding to a variety of contexts.
2. Explain the algorithm for finding circumference or area of a circle.	I can't explain why the algorithm for circumference or area of a circle works or where it came from.	I can sort of explain why the algorithm for circumference or area of a circle works or where it came from.	I can explain why the algorithm for circumference or area of a circle works or where it came from using pictures and words.	I can explain why the algorithm for circumference or area of a circle works or where it came from using pictures and words. I can also apply my understanding to a variety of contexts.
3. Find the circumference or area of any circle given the diameter or radius; or given circumference or area determine the diameter or radius.	I struggle to find the circumference and/or area of a circle given the diameter or radius AND/OR determine the diameter or radius given the circumference or area.	I can usually find the circumference or area of a circle given the diameter or radius AND/OR determine the diameter or radius given the circumference or area.	I can always find the circumference or area of a circle given the diameter or radius AND/OR determine the diameter or radius given the circumference or area.	I can always find the circumference or area of a circle given the diameter or radius AND/OR determine the diameter or radius given the circumference or area. I can also apply my understanding to a variety of contexts.

Sample Problems for Section 5.3

1. Use pictures and/or words to explain:
 - a. The relationship between the diameter of a circle and its circumference

 - b. The relationship between the diameter of a circle and its area

2. Use pictures and/or words to explain:
 - a. The algorithm for finding the circumference of a circle

 - b. The algorithm for finding the area of a circle

3. Use the given information to find the missing information. Give each answer exactly and rounded to the nearest hundredth unit.
 - a. Radius: 2 m
Circumference: _____
 - b. Diameter: 2 m
Circumference: _____
 - c. Radius: 5.5 in
Area: _____
 - d. Diameter: 40 in
Area: _____
 - e. Circumference: 69.08 cm
Diameter: _____
 - f. Area: 153.86 cm²
Radius: _____

Section 5.4: Angle Relationships

Section Overview: In this sections students will learn and begin to apply angle relationships for vertical angles, complementary angles and supplementary angles. They will practice the skills learned in this section further in Chapter 6 when they write equations involving angles. Students will also use concepts involving angles to relate scaling of triangles and circles. At the end of this section there is a review activity to help students tie concepts together.

Concepts and Skills to be Mastered (from standards)

Geometry Standard 5: Use facts about supplementary, complementary, vertical, and adjacent angles in a multi-step problem to write and solve simple equations for an unknown angle in a figure.

Geometry Standard 6: Solve real-world and mathematical problems involving area, volume and surface area of two- and three-dimensional objects composed of triangles, quadrilaterals, polygons, cubes, and right prisms. 7.G.6

1. Identify vertical, complementary and supplementary angles.
2. Find the measures of angles that are vertical, complementary or supplementary to a known angle.
3. Apply angle relationships to find missing angle measures. Given angle measures, determine the angle relationship.

5.4a Classwork: Special Angle Relationships

This diagram is a regular pentagon with all its diagonals drawn and all points labeled.

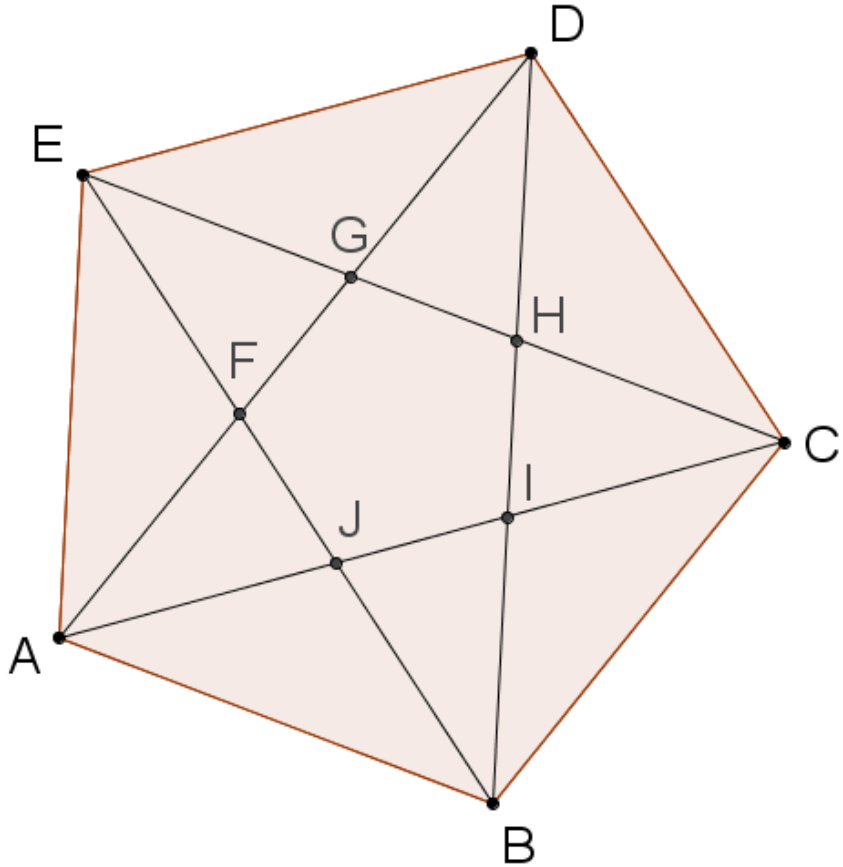

1. How many *non-overlapping* angles are in the diagram?

35

2. There are groups of angles that all have the same measure. For example, $\angle DEG$ and $\angle AEF$ have the same measure. How many *different measures* of angles are there in the diagram? Use a protractor.

3

Vertical Angles: Two lines that intersect form vertical angles. Vertical angles are pairs of angles that are always opposite one another (rather than adjacent to each other). For example, $\angle EFG$ and $\angle AFJ$ are vertical angles.

Adjacent Angles: Two angles are adjacent if they have a common ray (side) and vertex. For example, $\angle EFG$ and $\angle EFA$ are adjacent angles.

3. Name at least five vertical angle pairs. Use a different colored pencil to mark each pair in the diagram above.
4. Name at least five adjacent angle pairs. Use a different colored
5. What seems to be the relationship between measures of two vertical angles? Draw another pair of vertical angles below by constructing two intersecting lines and measure the two angles in the vertical pair. Does this example support your conjecture?

Vertical angles have the same measurement.

$\angle DGE$ and $\angle EGF$ are called *supplementary angles* because their measures add to 180° . When supplementary angles are adjacent, you can see that they form a straight line with the two outside rays. Supplementary angles don't always have to be next to each other.

6. Find and name at least 5 pairs of supplementary angles in the diagram. Use a different color to mark each pair in the diagram.

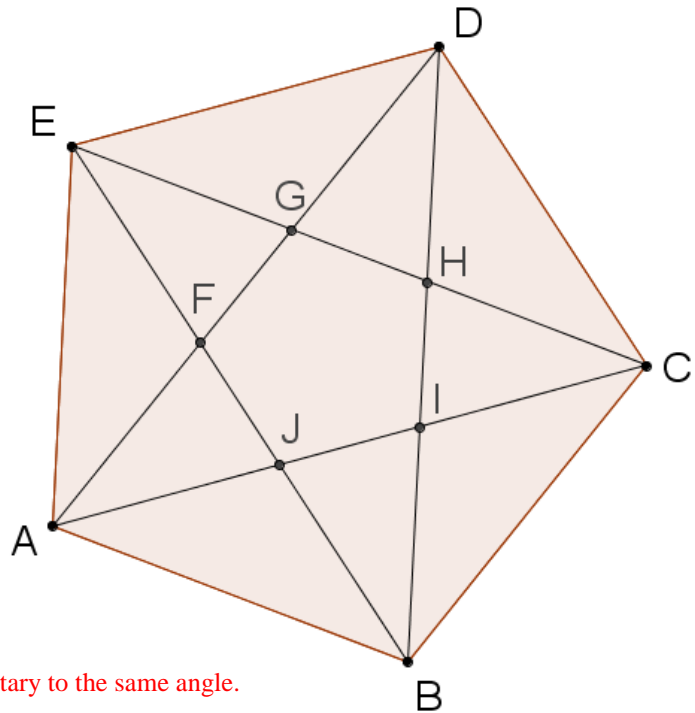

For #6 and #7, note that vertical angles are both supplementary to the same angle.

7. For each pair of intersecting lines below, find the three missing measures of angles formed. Justify your answer in the table.

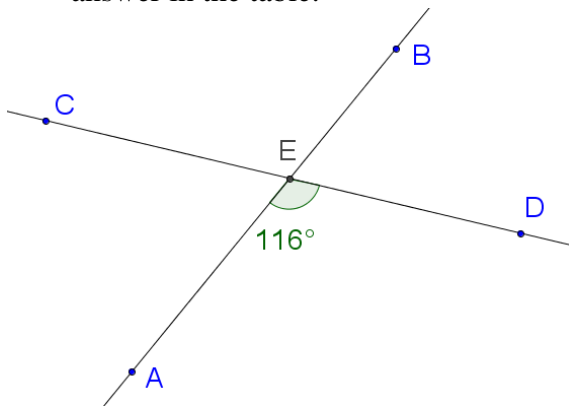

Angle	Measure of angle	Justification
$\angle CEB$	116°	Vertical angle to $\angle AED$
$\angle DEB$	64°	Supplementary to $\angle AED$
$\angle AEC$	64°	Supplementary to $\angle AED$

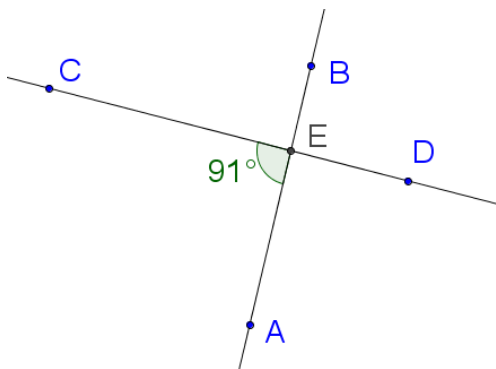

Angle	Measure of angle	Justification
$\angle CEB$	89°	Supplementary to $\angle AEC$
$\angle DEB$	91°	Vertical to $\angle AEC$
$\angle AED$	89°	Supplementary to $\angle AEC$

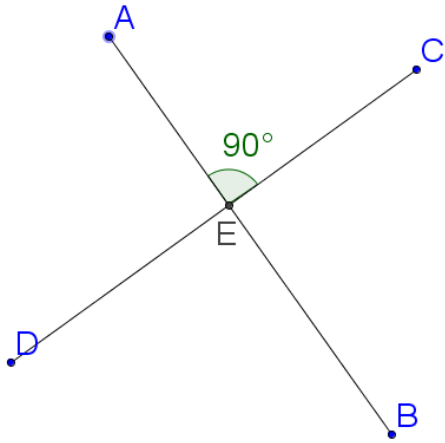

Angle	Measure of angle	Justification
$\angle CEB$	90°	Supplementary to $\angle AEC$
$\angle DEB$	90°	Vertical to $\angle AEC$
$\angle AED$	90°	Supplementary to $\angle AEC$

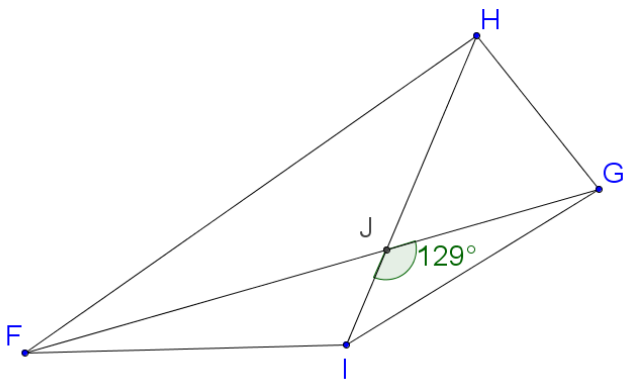

Angle	Measure of angle	Justification
$\angle FJI$		
$\angle HJG$		
$\angle FJH$		

8. For this rectangle with diagonals drawn in, there is one place where you can see supplementary and vertical angles. Use a protractor to measure one of the angles, and then calculate the measures of the other three angles that have vertex at E using facts about vertical and supplementary pairs.

$$\begin{aligned} \angle AED &= 60^\circ \\ \angle DEC &= 120^\circ \\ \angle DEB &= 60^\circ \\ \angle BEA &= 120^\circ \end{aligned}$$

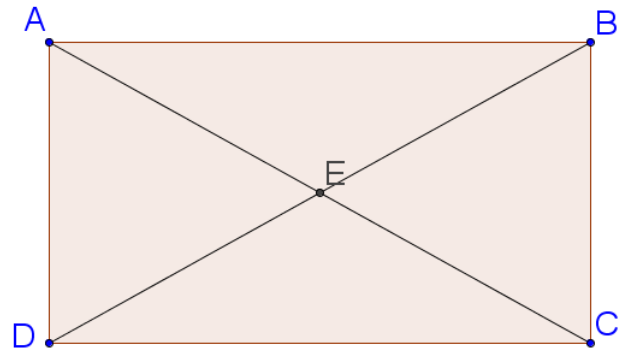

$\angle EAB$ and $\angle DAE$ are *complementary* because their measures add to 90° . When complementary angles are adjacent, you can see the right angle that is formed by the outside rays. However, complementary angles don't need to be adjacent; as long as their measures add to 90 degrees, two angles form a complementary pair.

9. Find and name at least five more pairs of complementary angles in the figure above. Use a different highlighter to mark each pair on the diagram.

10. Review: What is the sum of all the angles in a triangle?

The sum of the angles in a triangle is 180 degrees.

11. Consider a right triangle. What seems to be true about the two non-right angles in the triangle? Use the examples below, or draw your own examples to help with your conjecture.

The two non-right angles are complementary.

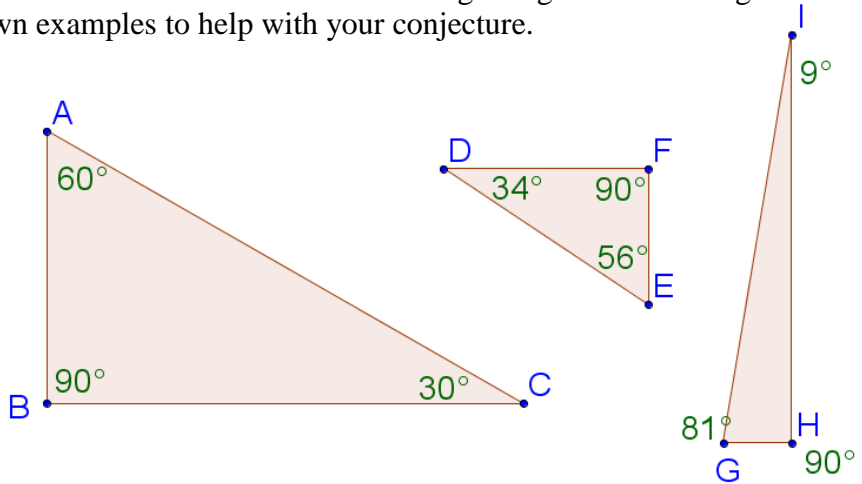

12. Look around the room you're in right now. Find examples of angles in the furniture, tiles, posters, etc. Can you see any complementary angles? Can you see supplementary angles? Can you see vertical angles? Draw sketches for at least three angle pairs you find.

For #13-14, use properties of complementary, supplementary, and vertical angles to find missing measures.

13. Two pair of seesaws sit unused at a playground, as shown. $\angle EGF$ has a measure of 140° .

a. Which angle is vertical to $\angle EGF$? $\angle CGH$

b. What is the measure of $\angle CGH$?

140°

c. Name an angle that is

supplementary to $\angle EGF$. $\angle CGE$

and $\angle HGF$

d. What is the measure of $\angle CGE$? 40°

e. What is the measure of $\angle HGF$? 40°

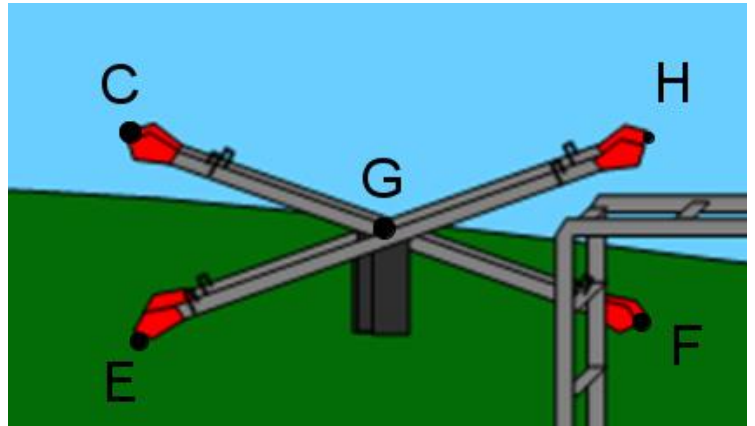

14. In the diagram below, $\angle ADB$ is a right angle. The figure is formed by 3 intersecting lines.

Fill in the measures and justifications in the table:

Angle	Measure	Justification
$\angle CDA$	90°	Supplementary to $\angle ADB$, which is 90° .
$\angle ADG$	24°	Vertical to $\angle EDF$
$\angle GDB$	66°	Complimentary to $\angle ADG$
$\angle BDF$	90°	Supplementary to $\angle ADB$
$\angle EDC$	66°	Complimentary to $\angle EDF$

Spiral Review

1. Order the numbers from least to greatest. $-\frac{1}{2}$, $\frac{1}{4}$, $-\frac{1}{4}$, -1.2 , -1.02 , $-.75$ -1.2 , -1.02 , $-.75$, $-\frac{1}{2}$, $-\frac{1}{4}$, $\frac{1}{4}$

2. Find the quotient: $-\frac{8}{9} \div \left(-\frac{3}{4}\right)$ $32/27$

3. Find the unit rate for BOTH units.

Izzy drove 357 miles on 10 gallons of gasoline. $\frac{357}{10} = \frac{35.7 \text{ miles}}{1 \text{ gal}}$ and $\frac{10}{357} = \frac{.028 \text{ gal}}{1 \text{ mile}}$

4. Convert the following units using the ratios given:

_____ $3\frac{1}{12}$ _____ feet = 37 inches (1 foot = 12 inches)

5. The temperature at midnight was 8° C. By 8 AM, it had risen 1.5° . By noon, it had risen a additional 2.7° . Then at 6 PM a storm blew in causing it to drop 4.7° . What was the temperature at 6 PM? 7.5°

5.4a Homework: Special Angle Relationships

1. Find at least one example of each angle relationship in the diagram. Name the angle pairs below, and highlight the pairs of angles in the diagram, using a different color for each relationship.

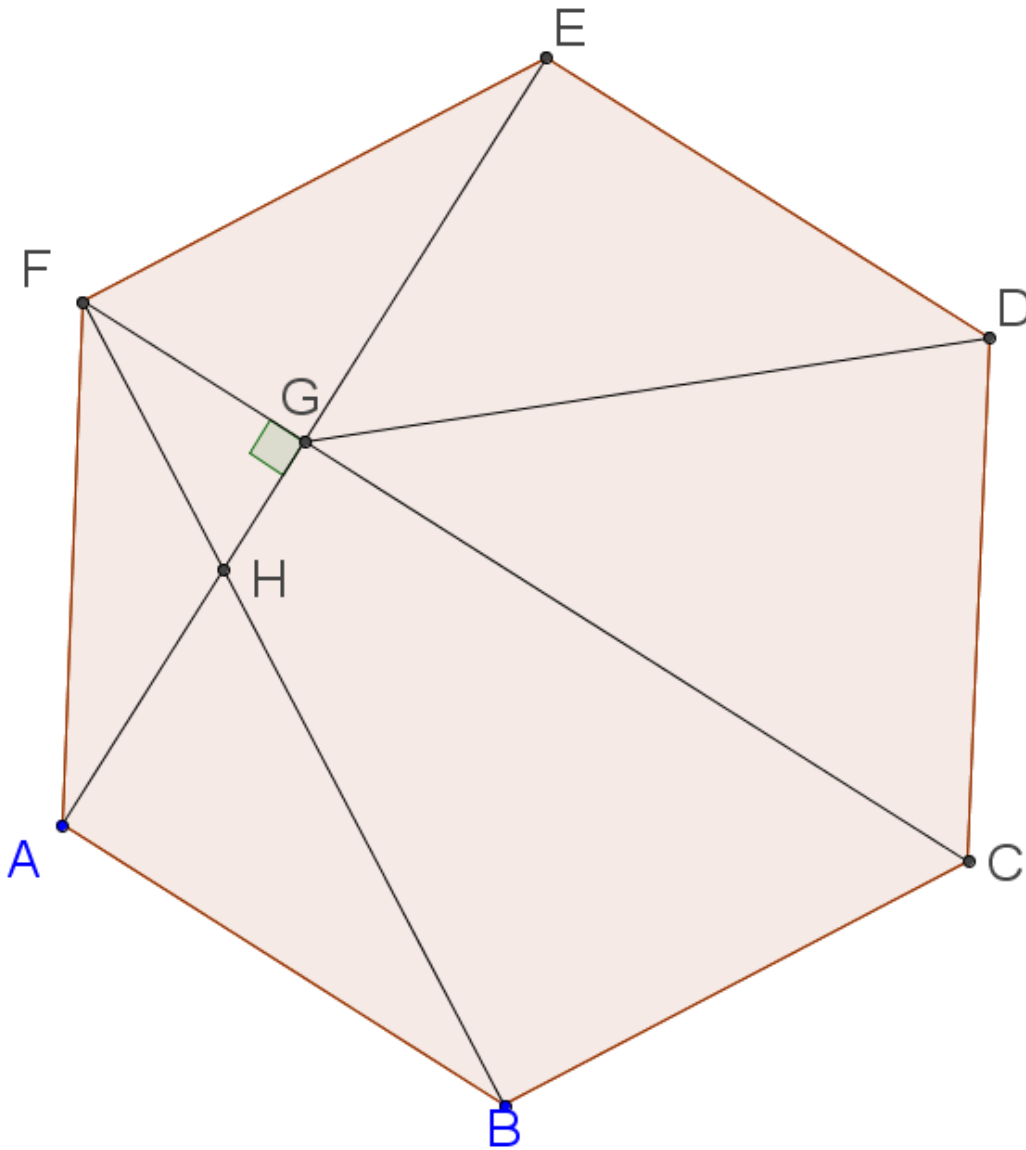

- a) Vertical angles
- b) Supplementary angles
- c) Complementary angles

2. For each figure of two intersecting lines, calculate the three missing measures, justifying your answer.

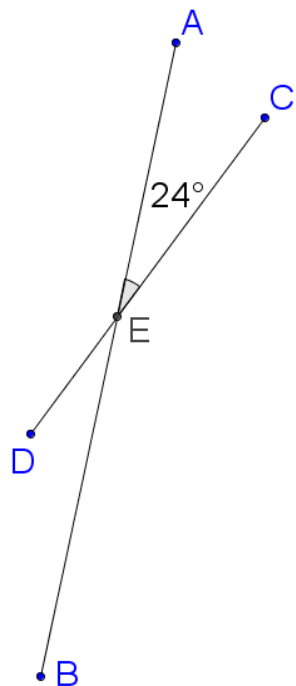

Angle	Measure of angle	Justification
$\angle CEB$	156°	Supplementary to $\angle AEC$
$\angle DEA$		
$\angle BED$		

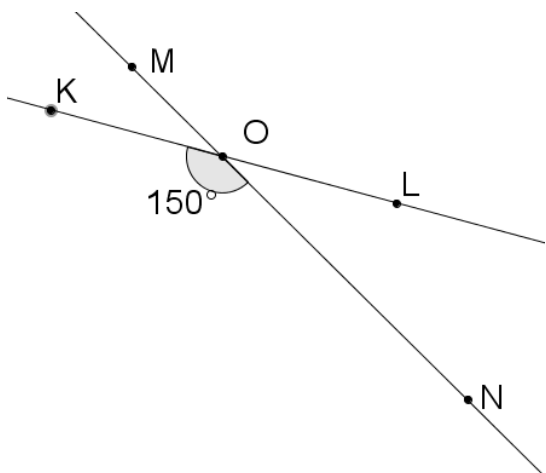

Angle	Measure of angle	Justification
$\angle LOM$		
$\angle MOK$		
$\angle NOL$		

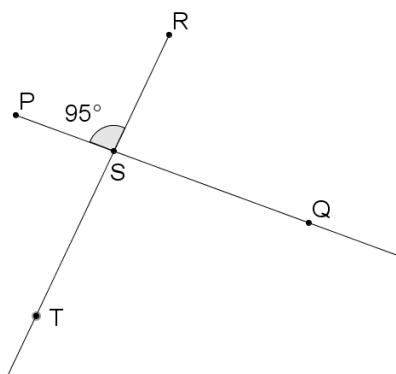

Angle	Measure of angle	Justification
$\angle PST$		
$\angle RSQ$	85°	Supplementary to $\angle PSR$
$\angle QST$		

3. For the figure formed by three intersecting lines, calculate the four missing measures, justifying your answer.

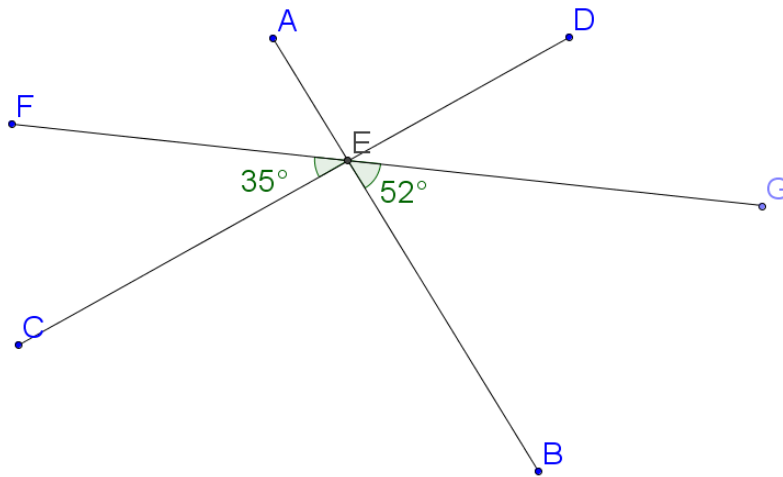

Angle	$\angle AEF$	$\angle AEC$	$\angle AED$	$\angle DEG$	$\angle CEB$	$\angle FEG$
Measure	52°					
Justification	Vertical to $\angle GEB$					

4. Refer to the figure below.

$m\angle AZU = 63^\circ$ because it is complimentary to $\angle AZW$

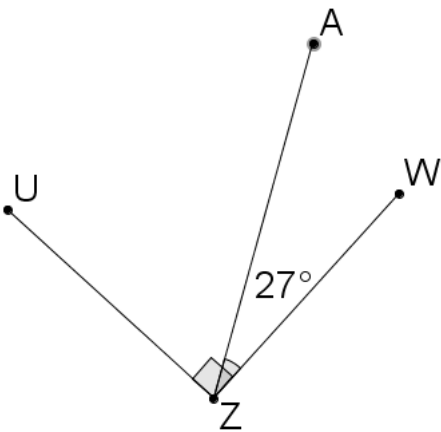

5. Fill in the missing angle measurements in the table, and give a justification for each measurement.

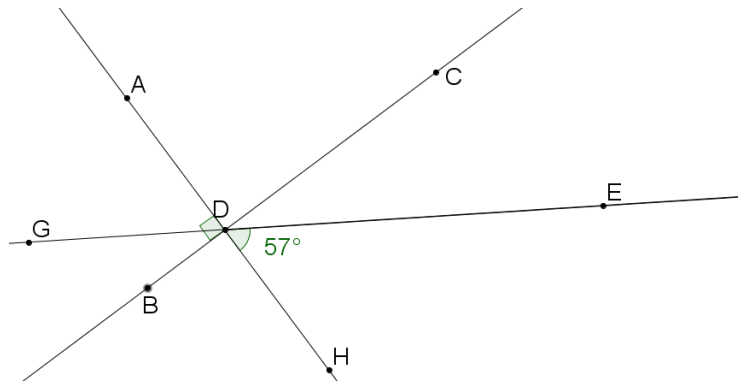

Angle	$\angle ADG$	$\angle GDB$	$\angle BDH$	$\angle CDH$	$\angle CDE$	$\angle CDA$
Measure	57°	33°		90°		
Justification	Vertical to $\angle EDH$	Complimentary to $\angle ADG$		Vertical to $\angle ADB$		

For #6-8, draw a diagram to illustrate the situation, and then choose the correct answer.

6. If $\angle G$ is complementary to $\angle H$, and $m\angle H = 20^\circ$, then $\angle G$ must be:

- a. Obtuse
- b. Acute**
- c. Right

7. If $\angle B$ is supplementary to $\angle C$, and $m\angle C = 90^\circ$, then $\angle B$ must be:

- d. Obtuse
- e. Acute
- f. Right

8. If $\angle D$ is vertical to $\angle E$, and $m\angle E = 115^\circ$, then $\angle D$ must be:

- g. Obtuse
- h. Acute
- i. Right

5.4b Classwork: Circles, Angles, and Scaling

Examine the figures below. \overline{BC} has a length of 5 units.

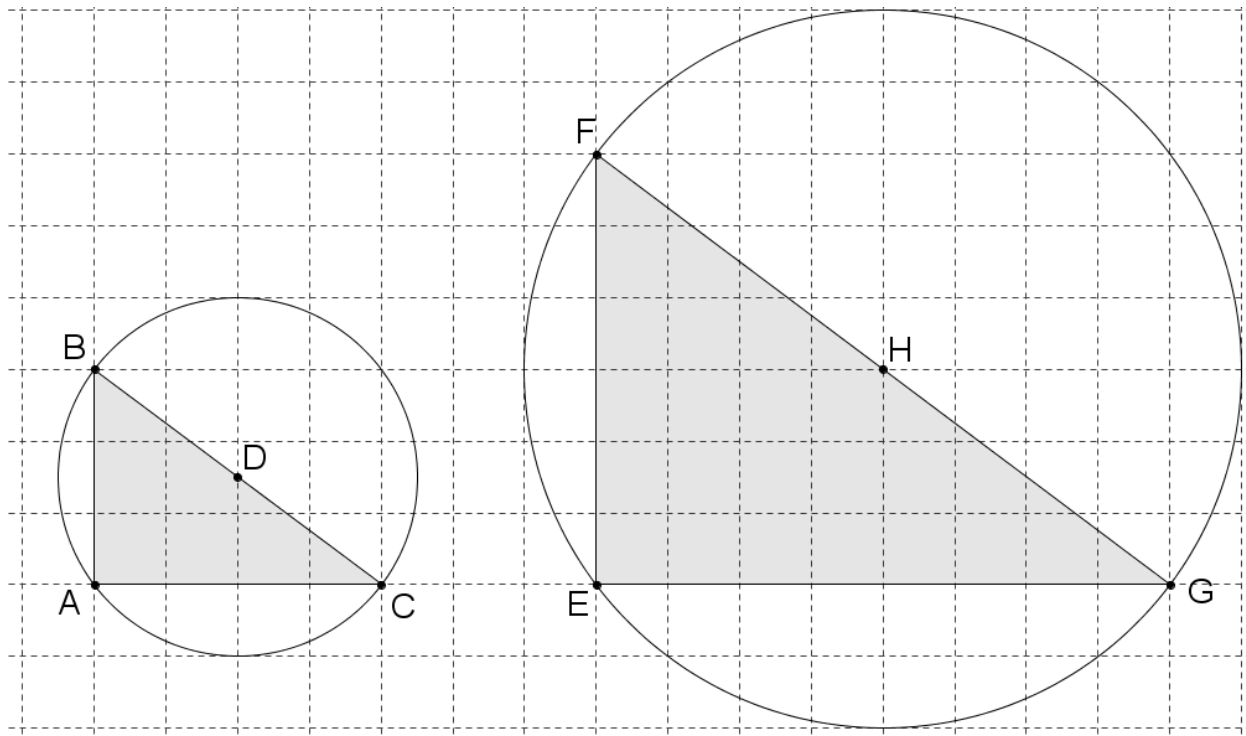

1. Write a complete sentence explaining why the figures are scale drawings of each other. You may use a protractor. Use words like *corresponding angles*, *scale factor*, *corresponding sides*, *circle*.

See student responses. The angles at A and E are both right. AB & EF ; AC & EG , and BC & FG are all corresponding sides. The ratio of $AB:EF$ is 3:6; $AC:EG$ is 4:8; $BC:FG$ is 5:10. Because the scale factor from the small to the large figure is 2, we know that the area of the larger figure is 4 times that of the smaller. *This will all be discussed in the questions below.

2. Remember that you have been given that \overline{BC} has length 5. What is the radius of each circle? Justify your answer.

radius $\odot D = 2.5$, radius $\odot H = 5$, the scale factor between the two figures is 1:2

3. Calculate the area of each triangle.

Area $\triangle ABC = 6$ square units, Area $\triangle EFG = 24$ square units

4. Classify the triangles by their sides and angles.

They are both scalene right triangles.

5. Name two pairs of complementary angles in the figures.

$\angle ABC$ & $\angle ACB$ and $\angle EFG$ & $\angle EGF$

6. What is the area of each circle?

Area $\odot D = 6.25\pi$ or 19.63 sq. units, Area $\odot H = 25\pi$ or 78.54 sq. units

7. How many of the smaller circle would fit inside the bigger circle, if you could put all the area in without overlapping and with no empty space?

4

8. What is the circumference of each circle?

Circumference $\odot D = 5\pi$ or 15.71 units, Circumference $\odot H = 10\pi$ or 31.42 units

9. How many of the circumferences of the smaller circle equal the bigger circumference?

2

10. Fill in the blanks: When you enlarge a figure with a scale factor of two, the side lengths and circumference **double**_, the areas **multiply by 4**, and the angles **stay the same**_.

11. You could construct other figures that are similar to these two figures with a different scale factor. What would be the dimensions of the triangle with scale factor $\frac{1}{2}$ from the figure on the left? What would be the radius of the circle?

Triangle: dimensions 1.5 units by 2 units and the radius of the circle would be 1.25 units

12. Follow the steps below to create another figure in the space below:

- Make a dot for the center of a circle, and use a compass to construct a circle around that dot.
- Use a straightedge to draw in a diameter with endpoints labeled A and B .
- Choose any point on the edge of the circle, and label it C .
- Draw in segments AC and BC so you can see a triangle ABC inscribed in the circle.
- Measure the angles in the triangle, and classify the triangle.
- Are there any pairs of complementary angles? If so, name them. **Yes, $\angle CAB$ & $\angle ABC$.**

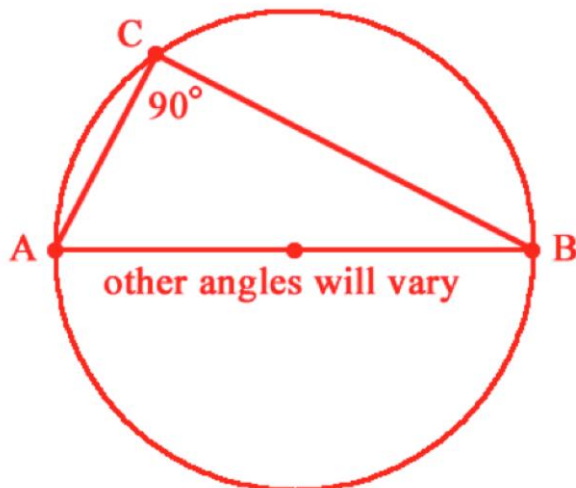

Extension: Honors students should explore why triangles inscribed on a semi circle are right triangles.

Spiral Review

1. Convert the following units using the ratios given: $\frac{3}{4}$ tons = 1500 pounds (1 ton = 2000 pounds)

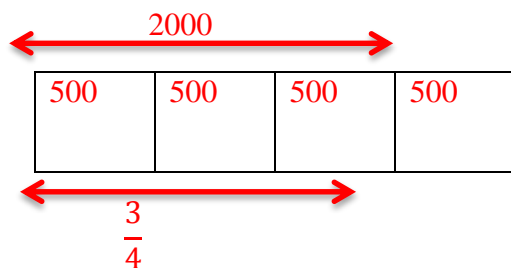

2. Solve the following proportion equations: $\frac{9}{x} = \frac{15}{25}$ $x = 15$

3. Without a calculator, what percent of 90 is 60? $66.\bar{6}\%$

4. Use a model to show $-17 + 5 = -12$



5. Alli owes her mom \$124. Alli made four payments of \$20 to her mom. How much does Alli now owe her mother?

$$124 - (20 \cdot 4) = 44$$

5.4b Homework: Review Assignment

Decide if the figures below are possible. Justify your conclusion with a mathematical statement. To construct the triangles use:

- A ruler or strips of centimeter graph paper cut to the given lengths
- A protractor
- Construction technology like GeoGebra

2. A triangle with angles that measure 20° , 70° , and 90° ?

Possible or not? Why or why not?

If so, what kind of triangle? Sketch, label.

3. A triangle with sides 8 and 3 cm. The angle opposite the 3 cm side measures 45° .

Possible or not? Why or why not?

If so, what is the measure of the 3rd side? Sketch, label.

Possible. The measure of the other side is approximately 10.

4. A triangle with sides of 8 cm and 3 cm. The angle opposite the 8 cm side measures 45° .

Possible or not? Why or why not?

5. Two students were building a model of a car with an actual length of 12 feet.

a. Andy's scale is $\frac{1}{4}$ inch = 1 foot. What is the length of his model? **3 inches**

b. Kate's scale is $\frac{1}{2}$ inch = 1 foot. What is the length of her model?

6. At Camp Bright the distance from the Bunk House to the Dining Hall is 112 meters and from the Dining Hall to the Craft Building is 63 meters (in the opposite direction). The scale of the a map for the camp is $0.5\text{cm} = 14\text{meters}$. On the map,...

- a. ...what is the scaled distance between the Bunk House and the Dining Hall?
- b. ...what is the scaled distance between the Dining Hall and the Craft Building?

Have student that struggle draw a model. A length of 112 meters has a total of eight 14 meter units. Each 14 meter unit is ONE 0.5 cm on the scaled map. Thus the length on the scaled map is 4 cm.

7. In the similar L figures,
- a. What is the ratio of height of left figure : height of right figure? $9:3$ or $3:1$
 - b. What is the reducing scale factor? $1/3$
 - c. What is the ratio of area of left figure: area of right figure? $36:4$ or $9:1$. The area scale factor will be the unit scale factor squared.

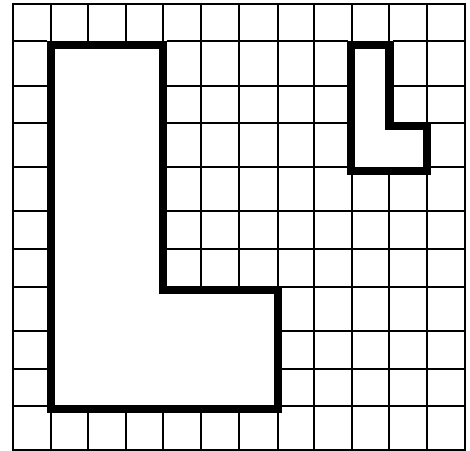

8. Triangles ABC and RST are scale versions of each other.

- d. What is the scale factor from $\triangle ABC$ to $\triangle RST$?
- e. What is the scale factor from $\triangle RST$ to $\triangle ABC$?
- f. What is the distance between A and C ?
- g. What is the distance between R and S ?
 $8 \times \frac{3}{4} = 6$

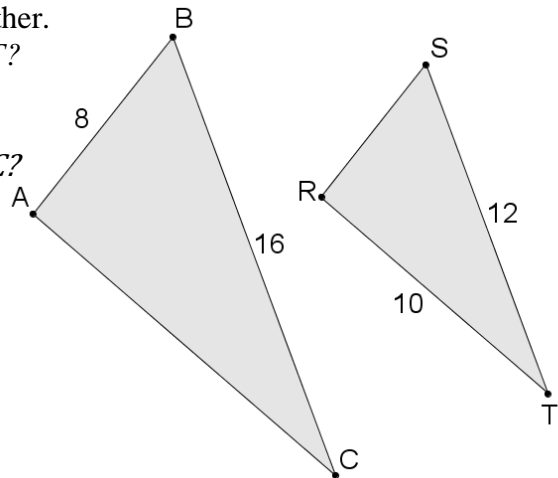

9. Redraw the figures at right using the scale factors below.

a. Use a scale factor of 4 to re-draw the square.

b. Use a scale factor of $\frac{1}{4}$ to re-draw the addition sign.

c. Use a scale factor of 1.5 to re-draw the division sign.

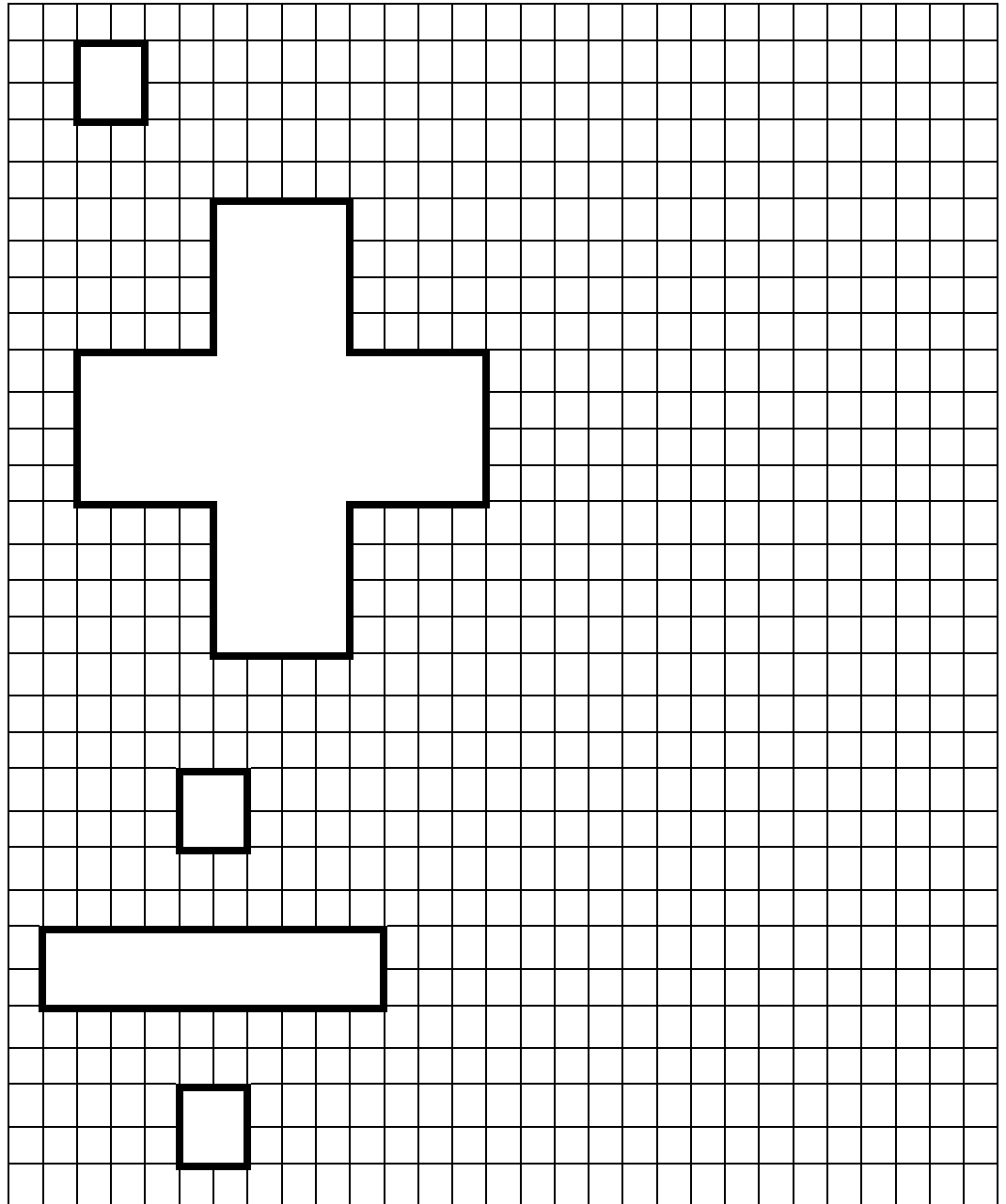

10. The Washington Monument is 555 feet and $5 \frac{1}{8}$ feet tall. Bob wants to create a scale model of it that is no more than 6 feet tall. What scale would you suggest Bob use for his model?

11. Calculate the circumference and area of the circles below. Express each measurements both exactly in terms of pi, and as an approximation to the nearest tenth of a unit.

a. $C = 0.5\pi \text{ cm}$

$C \approx 1.571 \text{ cm}$

$A = 0.06\pi \text{ sq. cm}$

$A \approx 0.196 \text{ sq. cm}$

b. $C =$

$C \approx$

$A = \approx$

$A \approx$

c. $C =$

$C \approx$

$A =$

$A \approx$

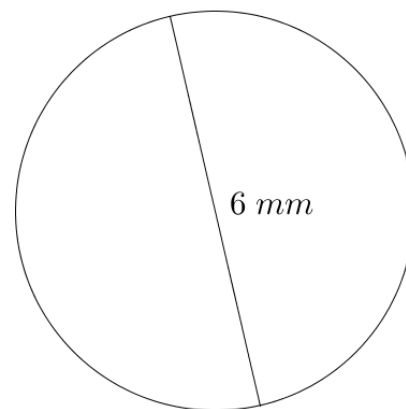
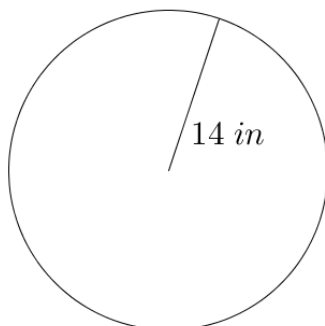
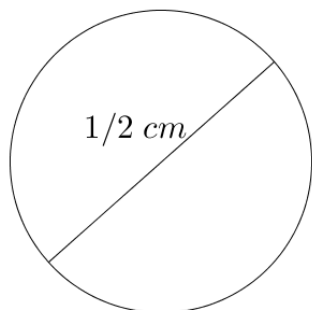

12. How many times would a circle with radius 4 units fit inside a circle with radius 12 units, if you could pack the area tightly with no overlapping and no leftover space?

13. Are all circles similar? Justify your answer.

14. Are all squares similar? Justify your answer.

Yes, because the ratio between the sides of all squares is 1:1

15. Are all rectangles scaled versions of each other? Justify your answer.

No, ratios can differ. This is an important question. All regular figures and circles are scaled versions of each other. Rectangles all have the same angles, but consecutive sides are not always in the same ratio.

16. A circle has an area of $144\pi \text{ mm}^2$. What is its circumference? Show your work.

17. Find the missing angle measures for the figure below. Justify each answer.

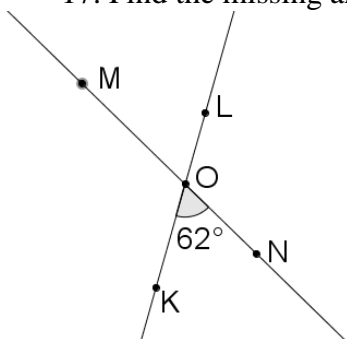

$\angle MOL = 62^\circ$, vertical to $\angle NOK$

$\angle LON = 118^\circ$, supplementary to $\angle NOK$

$\angle KOM = 118^\circ$, supplementary to $\angle NOK$

18. Find all the missing angle measures for the figure below. Justify each answer.

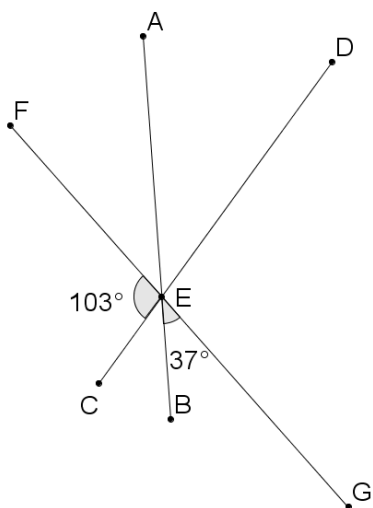

19. Draw and label two intersecting lines for which $\angle CDE$ and $\angle ADR$ are vertical angles.

20. Draw and label two intersecting lines for which $\angle HOG$ and $\angle GOX$ are supplementary.

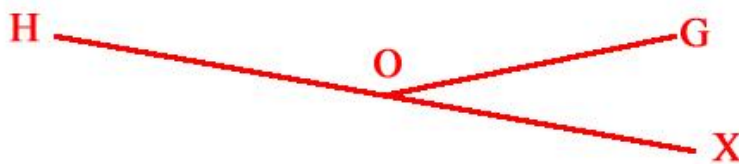

21. Draw and label a pair of adjacent complementary angles $\angle ABC$ and $\angle BCD$.

5.4c Self-Assessment: Section 5.4

Consider the following skills/concepts. Rate your comfort level with each skill/concept by checking the box that best describes your progress in mastering each skill/concept. Sample problems can be found on the following page.

Skill/Concept	Beginning Understanding	Developing Skill and Understanding	Practical Skill and Understanding	Deep Understanding, Skill Mastery
1. Identify vertical, complementary and supplementary angles.	I struggle to use the terms vertical, complementary and supplementary angles.	Most of the time I can identify vertical, complementary and supplementary angles.	I can identify vertical, complementary and supplementary angles.	I can identify vertical, complementary and supplementary angles. I can also explain the relationship of the measures of the angles in each angle relationship.
2. Find the measures of angles that are vertical, complementary or supplementary to a known angle.	I struggle to find measures of angles that are vertical, complementary and supplementary angles to a known angle.	I can usually find measures of angles that are vertical, complementary and supplementary angles to a known angle.	I can find the measure of angles that are vertical, complementary or supplementary to a known angle.	I can find the measure of angles that are vertical, complementary or supplementary to a known angle. I can justify how I solved for the missing angle.
3. Apply angle relationships to find missing angle measures. Given angle measures, determine the angle relationship.	I struggle to find measures of angles using angle relationships.	I can usually find measures of angles that are vertical, complementary and supplementary to other angles. I can also usually identify relationships given angle measures.	I can always find measures of angles that are vertical, complementary and supplementary to other angles. I can also usually identify relationships given angle measures.	I can always find measures of angles that are vertical, complementary and supplementary to other angles. I can also usually identify relationships given angle measures. I can also explain how these relationships are similar and different.

Sample Problems for Section 4.4

1. Identify the shaded angle pairs diagramed below as vertical, supplementary, or complementary.

a.

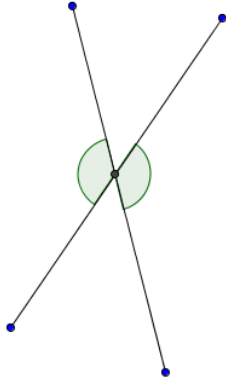

c.

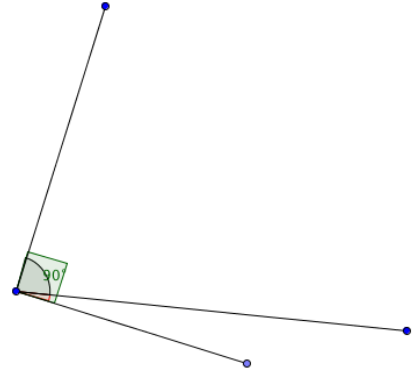

b.

d.

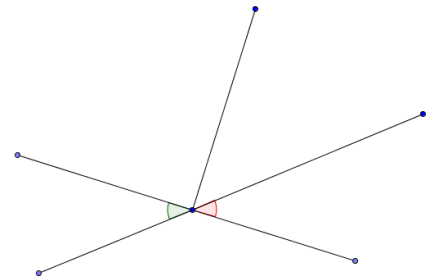
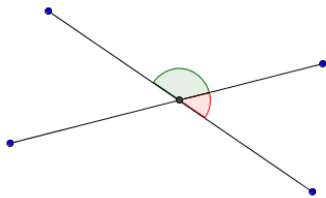

2. Use the relationship given to find the missing angle.

- a. If $\angle G$ is complementary to $\angle H$, and $m\angle H = 52^\circ$, then $\angle G$ must be _____.
- b. If $\angle J$ is supplementary to $\angle K$, and $m\angle J = 168^\circ$, then $\angle K$ must be _____.
- c. If $\angle N$ is vertical to $\angle M$, and $m\angle M = 98^\circ$, then $\angle N$ must be _____.

3. In the diagram below, find all missing angles. Justify with the appropriate angle relationship.

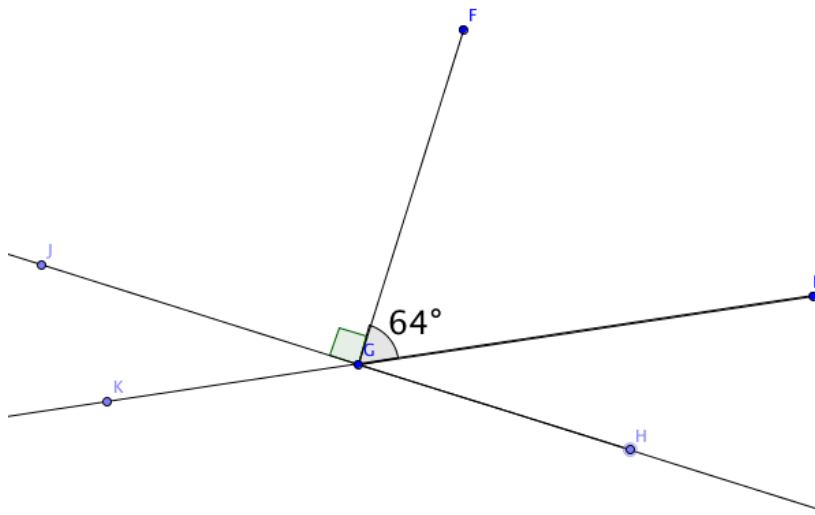

Angle	Measure	Justification
$\angle FGH$		
$\angle IGH$		
$\angle KGH$		
$\angle KGI$		

4. Given the measures of the following angles, identify the possible angle relationship(s).

a. $m\angle ABC = 10^\circ$ and $m\angle DBC = 80^\circ$

b. $m\angle ABC = 24^\circ$ and $m\angle EBF = 24^\circ$