

First published in 2013 by the University of Utah in association with the Utah State Office of Education.

Copyright © 2013, Utah State Office of Education. Some rights reserved.

This work is published under the Creative Commons Attribution License (“CC BY”) which is available online at <http://creativecommons.org/licenses/by/3.0/> and provides permissions for the reusing, revising, remixing, and redistributing of this work. This work is an *open educational resource* (OER).

Table of Contents

CHAPTER 6: REAL WORLD EQUATIONS AND INEQUALITIES (2-3 WEEKS)	2
SECTION 6.1 WRITE AND SOLVE EQUATIONS TO FIND UNKNOWN IN GEOMETRIC SITUATIONS.....	5
<i>Class Activity: Solving Equations Review</i>	6
<i>Homework: Solving equations review</i>	8
6.1a <i>Class Activity: Complementary, Supplementary, Vertical, Adjacent Angles</i>	9
6.1a <i>Homework: Complementary, Supplementary, Vertical, Adjacent Angles</i>	13
6.1b <i>Class Activity: Angle Pairs and Solving Equations</i>	16
6.1b <i>Homework: Angle Pairs and Solving Equations</i>	19
6.1c <i>Class Activity: Perimeter and Area with Variables</i>	22
6.1c <i>Homework: Perimeter and Area with Variables</i>	25
6.1d <i>Class Activity: Triangles and Circles</i>	28
6.1d <i>Homework: Triangles and Circles</i>	31
6.1e <i>Self-Assessment: Section 6.1</i>	35
SECTION 6.2 WRITE AND SOLVE EQUATIONS FROM WORD PROBLEMS	39
<i>Anchor Problem: Cookies for a Party</i>	40
6.2a <i>Class Activity and Homework: Write and Solve Equations for Word Problems I</i>	41
6.2b <i>Class Activity and Homework: Write Word Problems for Equations I</i>	45
6.2c <i>Class Activity: Write and Solve Equations for Word Problems II</i>	50
6.2c <i>Homework: Write and Solve Equations for Word Problems II</i>	53
6.2d <i>Class Activity: Write and Solve Equations from Word Problems III</i>	56
6.2d <i>Homework: Write and Solve Equations from Word Problems III</i>	60
6.2e <i>Extra Practice: Write and Solve Equations</i>	63
6.2f <i>Self-Assessment: Section 6.2</i>	65
6.3 SOLVE AND GRAPH INEQUALITIES, INTERPRET INEQUALITY SOLUTIONS.....	68
6.3a <i>Class Activity and Homework: Review of Inequality Statements</i>	69
6.3b <i>Class Activity: Solve and Graph Inequalities</i>	73
6.3b <i>Homework: Solve and Graph Inequalities</i>	76
6.3c <i>Class Activity: Multiplying by a negative when Solving Inequalities</i>	78
6.3c <i>Homework: Multiplying by a negative when Solving Inequalities</i>	81
6.3d <i>Class Activity: Write and Solve Inequalities for Word Problems</i>	83
6.3d <i>Homework: Write and Solve Inequalities for Word Problems</i>	86
6.3e <i>Class Activity: Solve Inequalities Review</i>	88
6.3f <i>Self-Assessment: Section 6.3</i>	93

Chapter 6: Real World Equations and Inequalities (2-3 Weeks)

UTAH CORE Standard(s)

1. Understand that rewriting an expression in different forms in a problem context can shed light on the problem and how the quantities in it are related. *For example, $a + 0.05a = 1.05a$ means that “increase by 5%” is the same as “multiply by 1.05.”* 7.EE.A.2
2. Solve multi-step real-life and mathematical problems posed with positive and negative rational numbers in any form (whole numbers, fractions, and decimals), using tools strategically. Apply properties of operations to calculate with numbers in any form; convert between forms as appropriate; and assess the reasonableness of answers using mental computation and estimation strategies. *For example: If a woman making \$25 an hour gets a 10% raise, she will make an additional $\frac{1}{10}$ of her salary an hour, or \$2.50, for a new salary of \$27.50. If you want to place a towel bar $9\frac{3}{4}$ inches long in the center of a door that is $27\frac{1}{2}$ inches wide, you will need to place the bar about 9 inches from each edge; this estimate can be used as a check on the exact computation.* 7.EE.B.3
3. Use variables to represent quantities in a real-world or mathematical problem, and construct simple equations and inequalities to solve problems by reasoning about the quantities. 7.EE.B.4
 - a. Solve word problems leading to equations of the form $px + q = r$ and $p(x + q) = r$, where p , q , and r are specific rational numbers. Solve equations of these forms fluently. Compare an algebraic solution to an arithmetic solution, identifying the sequence of the operations used in each approach. *For example, the perimeter of a rectangle is 54 cm. Its length is 6 cm. What is its width?* 7.EE.B.4a
 - b. Solve word problems leading to inequalities of the form $px + q > r$ or $px + q < r$, where p , q , and r are specific rational numbers. Graph the solution set of the inequality and interpret it in the context of the problem. *For example: As a salesperson, you are paid \$50 per week plus \$3 per sale. This week you want your pay to be at least \$100. Write an inequality for the number of sales you need to make, and describe the solutions.* 7.EE.B.4b
4. Use facts about supplementary, complementary, vertical, and adjacent angles in a multi-step problem to write and solve simple equations for an unknown angle in a figure. 7.G.5

CHAPTER OVERVIEW:

This chapter brings together several ideas. The theme throughout however is writing equations or inequalities to represent contexts. In the first section students work with ideas in geometry and represent their thinking with equations. Also in that section students solidify their understanding of the relationship between measuring in one-, two-, and three-dimensions. In the second section, students will be writing equations for a variety of real life contexts and then finding solutions. The last section explores inequalities. This is the first time students think about solutions to situations as having a range of answers.

VOCABULARY:

algebraic, inequality, equation, inverse operations, solution, at most, at least, less than, greater than, $<$, $>$, \leq , \geq , supplementary, complementary, vertical angles, adjacent angles, intersecting lines

CONNECTIONS TO CONTENT:

Prior Knowledge







In Chapter 3 students learned how to solve one-step and simple multi-step equations using models. In this chapter students extend that work to more complex contexts. In particular they build on understandings developed in Chapter 5 about geometric figures and their relationships. Work on inequalities in this chapter

builds on 6th grade understandings where students were introduced to inequalities represented on a number line. In this chapter student move to solving simple one-step inequalities. Also by this chapter, students should move to representing ideas symbolically rather than with models.

Future Knowledge

Throughout mathematics, students need to be able to model a variety of contexts with algebraic expressions and equations. Further, algebraic expressions help shed new light on the structure of the context. Thus the work in this chapter helps to move students to thinking about concrete situations in more abstract terms. Lastly, by understanding how an unknown in an expressions/equations can represent a “fixed” quantity, students will be able to move to contexts where the unknown can represent variable amounts (i.e. functions in 8th grade.)

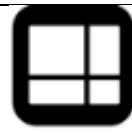
MATHEMATICAL PRACTICE STANDARDS (emphasized):

	Make sense of problems and persevere in solving them.	Students must read, interpret and understand problem situation and transfer that understanding to algebraic equations or inequalities that represent the context. Students should develop flexible strategies for doing this work that will extend to more complicated situations. Additionally, students should make reasonable predictions about what they believe their final answer will be and then use that to both guide their strategy for writing expressions and equations and for checking their answer.
	Reason abstractly and quantitatively.	Students should fluidly connect problem contexts to algebraic representations of them. Each portion of the expression (e.g. variables, operations, groupings etc.) should connect to the context and the abstract representation should shed new light on context.
	Construct viable arguments and critique the reasoning of others.	Students are able to explain and defend the reasonableness of their answer by connecting the context to the abstract representation. Further, students should be able to critique the work of others by connecting the context to the algebraic expression and/or equation.
	Model with Mathematics.	Students will model a variety of contexts with algebraic expressions and equations. Further, students should be able to take an algebraic expression or equation and model it with a context.
	Attend to Precision	Students should use precision in translating between contexts and abstract representations. For example, students should understand when two expressions should be “equal” versus “greater than or equal to” each other OR distinguish when a quantity is being “increased by two” versus “increased by a <i>factor</i> of two.”
	Look for and make use of structure	Students should recognize and interpret structures both within a context and an algebraic expression/equation. Structures either in contexts or in abstract representations should shed light on how to solve a problem and the reasonableness of an answer.
	Use appropriate tools strategically.	Students demonstrate their ability to select and use the most appropriate tool (paper/pencil, manipulatives, pictorial models and calculators) while solving real-life word problems. By this chapter, students should recognize that their ability to reason through computations is often much faster than using a calculator.
	Look for and express regularity in repeated reasoning	Students look for structure and patterns in real-life contexts to help them identify solution strategies. Further, students should begin to recognize how things are <i>changing</i> in a context (operationally.) In 7 th grade the change is fixed and equations help us find one unknown but in 8 th grade students begin to understand change can be continuous (as in functions) and they begin to see how an unknown can represent a variable quantity.

Section 6.1 Write and Solve Equations to Find Unknowns in Geometric Situations.

Section Overview: This section builds upon what students learned about geometric relationships in chapter 5 and in earlier grades. Students start with a review of solving equations. They then move to applying those skills to writing and solving one-step and multi-step equations involving finding missing measures of unknown values in contexts involving various angle relationships with triangles, areas, perimeters, circles and scaling. Students should pay close attention to the relationship between the structure of algebraic equations and expressions and the contexts they represent.

Concepts and Skills to be Mastered (from standards)

By the end of this section, students will be able to:

1. Use properties of supplementary, complementary, vertical, and adjacent angles to solve for unknown angles in figures.
2. Write and solve equations based on a diagram of intersecting lines with some known angle measures.
3. Write and solve equations to find the measure of a missing angle in a triangle.
4. Write and solve equations to find the radius or diameter given the area or circumference of a circle.
5. Write and solve equations using a scale factors.
6. Write and solve equations to find areas, perimeters, or unknown lengths of polygonal figures.

Class Activity: Solving Equations Review

In Chapter 3, you learned to solve various equations using models. *If necessary*, use the Key to draw a model to solve the following equations:

<p><i>Key for Tiles:</i></p> <div style="display: flex; justify-content: space-around; align-items: center;"> <div style="text-align: center;"> <div style="border: 1px solid black; padding: 5px; width: 30px; height: 30px; display: flex; align-items: center; justify-content: center;">1</div> = 1 </div> <div style="text-align: center;"> <div style="border: 1px solid black; padding: 5px; width: 60px; height: 30px; display: flex; align-items: center; justify-content: center;">x</div> = x </div> </div> <div style="display: flex; justify-content: space-around; align-items: center; margin-top: 10px;"> <div style="text-align: center;"> <div style="border: 1px solid black; padding: 5px; width: 30px; height: 30px; display: flex; align-items: center; justify-content: center; background-color: #f0f0f0;">-1</div> = -1 </div> <div style="text-align: center;"> <div style="border: 1px solid black; padding: 5px; width: 60px; height: 30px; display: flex; align-items: center; justify-content: center; background-color: #f0f0f0;">-x</div> = -x </div> </div>	
--	--

Model the Equation	What are the solving action? Record the steps using Algebra	Check solution in the equation.
<p>1. $2x + 7 = 9$</p> <div style="border: 2px solid black; padding: 10px; display: flex; align-items: center; justify-content: center;"> <div style="border: 1px solid black; padding: 5px; width: 150px; height: 150px; display: flex; flex-direction: column; align-items: center; justify-content: center;"> <div style="border: 1px solid black; padding: 5px; width: 80%; height: 30px; margin-bottom: 5px;">x</div> <div style="border: 1px solid black; padding: 5px; width: 80%; height: 30px; margin-bottom: 5px;">x</div> <div style="display: flex; justify-content: space-around; width: 80%;"> <div style="border: 1px solid black; padding: 5px; width: 20px; height: 20px; display: flex; align-items: center; justify-content: center;">1</div> <div style="border: 1px solid black; padding: 5px; width: 20px; height: 20px; display: flex; align-items: center; justify-content: center;">1</div> <div style="border: 1px solid black; padding: 5px; width: 20px; height: 20px; display: flex; align-items: center; justify-content: center;">1</div> <div style="border: 1px solid black; padding: 5px; width: 20px; height: 20px; display: flex; align-items: center; justify-content: center;">1</div> </div> <div style="display: flex; justify-content: space-around; width: 80%; margin-top: 5px;"> <div style="border: 1px solid black; padding: 5px; width: 20px; height: 20px; display: flex; align-items: center; justify-content: center;">1</div> <div style="border: 1px solid black; padding: 5px; width: 20px; height: 20px; display: flex; align-items: center; justify-content: center;">1</div> <div style="border: 1px solid black; padding: 5px; width: 20px; height: 20px; display: flex; align-items: center; justify-content: center;">1</div> </div> </div> = <div style="border: 1px solid black; padding: 5px; width: 150px; height: 150px; display: flex; flex-direction: column; align-items: center; justify-content: center;"> <div style="border: 1px solid black; padding: 5px; width: 30px; height: 30px; display: flex; align-items: center; justify-content: center; margin-bottom: 5px;">1</div> <div style="border: 1px solid black; padding: 5px; width: 30px; height: 30px; display: flex; align-items: center; justify-content: center; margin-bottom: 5px;">1</div> <div style="border: 1px solid black; padding: 5px; width: 30px; height: 30px; display: flex; align-items: center; justify-content: center; margin-bottom: 5px;">1</div> <div style="border: 1px solid black; padding: 5px; width: 30px; height: 30px; display: flex; align-items: center; justify-content: center; margin-bottom: 5px;">1</div> <div style="border: 1px solid black; padding: 5px; width: 30px; height: 30px; display: flex; align-items: center; justify-content: center; margin-bottom: 5px;">1</div> <div style="border: 1px solid black; padding: 5px; width: 30px; height: 30px; display: flex; align-items: center; justify-content: center; margin-bottom: 5px;">1</div> <div style="border: 1px solid black; padding: 5px; width: 30px; height: 30px; display: flex; align-items: center; justify-content: center; margin-bottom: 5px;">1</div> <div style="border: 1px solid black; padding: 5px; width: 30px; height: 30px; display: flex; align-items: center; justify-content: center; margin-bottom: 5px;">1</div> </div> </div>	<p><i>Add -7 to both sides.</i> <i>Divide by 2 on both sides.</i></p> $ \begin{array}{r} 2x + 7 \neq 9 \\ \underline{-7 \quad -7} \\ 2x \neq 2 \\ \underline{\quad \quad \neq} \\ 2 \neq 2 \\ \quad \quad \quad \neq \\ x \neq 1 \end{array} $	
<p>2. $-7 = 3x - 1$</p> <div style="border: 2px solid black; padding: 10px; display: flex; align-items: center; justify-content: center;"> <div style="border: 1px solid black; width: 150px; height: 150px;"></div> = <div style="border: 1px solid black; width: 150px; height: 150px;"></div> </div>		
<p>3. $0 = 3 - 7x + 10$</p> <div style="border: 2px solid black; padding: 10px; display: flex; align-items: center; justify-content: center;"> <div style="border: 1px solid black; width: 150px; height: 150px;"></div> = <div style="border: 1px solid black; width: 150px; height: 150px;"></div> </div>		

4. $(1/2)(3x - 4) = -8$

	=	
--	---	--

5. $(1/3)x - 6 = 2x + 1$

	=	
--	---	--

Solve the following either with or without a model.

6) $1 = 5x + 7 - 2x$

7) $-10 = (1/2)x - 3$

8) $(2/3)x + 4 = -2 + x$

9) $14 = -2(3x + 1)$

10) $-5 = (1/2)(3x - 1)$

11) $(-1/3)(2x + 5) = 7$

Homework: Solving equations review.

Solve the following equations. Draw a model if needed. Show all steps using Algebra. A calculator may be helpful.

1. $5x + 3 = -2$

2. $34 = -2(1 - 9x)$

3. $2(3x - 3) - 8 = 4$

4. $= 5$

5. $7x - 7 - 4 = -25$

6. $6(b - 5) = 30$

7. $2j - 6 - \frac{1}{2}j = -12$

8. $8(v + 1) = 4$

9. $2b - \frac{1}{9} = \frac{1}{3}$

10. $-5 + 75n + 1 = 146$

11. $357 = 3(x - 9)$

12. $48 = 15 + \frac{1}{3}d$

13. $48 - \frac{1}{3}d - \frac{2}{3}d = 50$



14. $8y + \frac{2}{3} = 9$

15. $0.75n + 1 - 0.25n = -100$

6.1a Class Activity: Complementary, Supplementary, Vertical, Adjacent Angles

Review: Chapter 5 concepts:

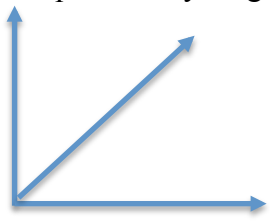
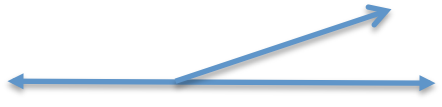
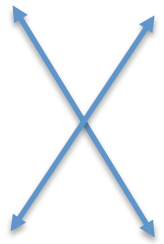
Draw an example for each type of angle pair then explain their relationship.

<p>1. Complementary Angles</p> 	<p>2. Supplementary Angles</p> 
<p>3. Vertical Angles</p> 	<p>4. Adjacent Angles</p> 

Identify whether the example pairs below are complementary, supplementary or neither.

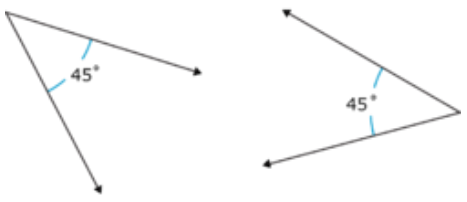
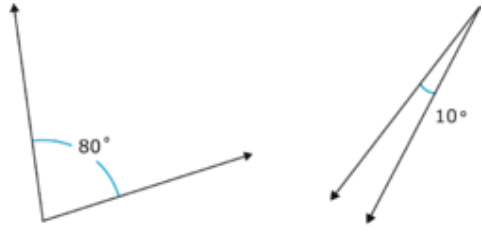
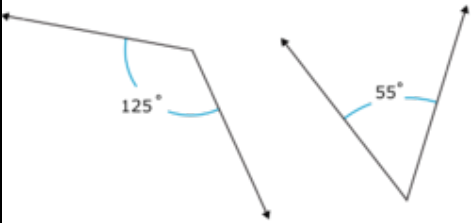
<p>5.</p> 	<p>6.</p> 
<p>7.</p> 	<p>8. Angle A = 37°, Angle B = 53°</p> <hr/> <p>9. Angle C = 110°, Angle B = 70°</p>

Find the measure of the identified angle:

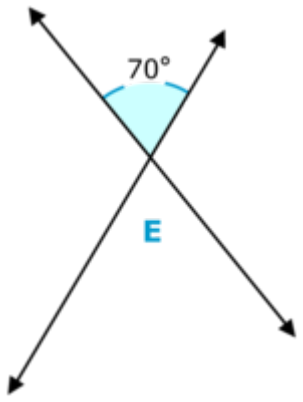
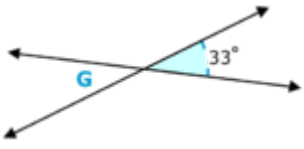
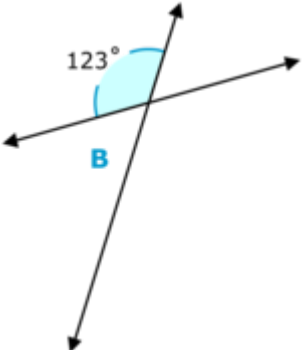
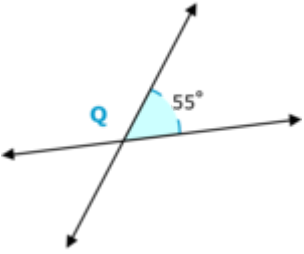
<p>10.</p> 	<p>11.</p> 
<p>Are the angles in #10 adjacent or vertical? Explain:</p>	<p>Are the angles in #11 adjacent or vertical? Explain:</p>
<p>12.</p> 	<p>13.</p> 
<p>Adjacent or vertical?</p>	<p>Adjacent or vertical?</p>

In 10-13 above the adjacent angle pairs are also examples of supplementary angles. Are adjacent angles always supplementary? Why or why not?

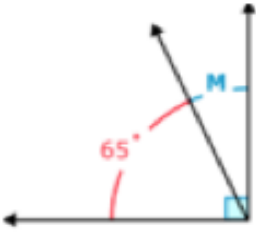
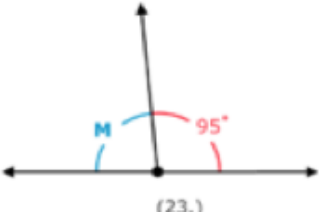
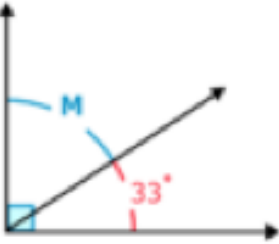
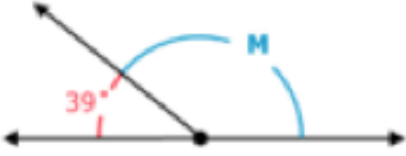

Use angle relationship (complementary, supplementary, vertical) to write a simple equation to find the missing angle (example: $180^\circ = 50^\circ + x$, or $x = 180^\circ - 50^\circ$)

<p>14.</p>  <p>(22.)</p>	<p>15.</p>  <p>(23.)</p>
<p>Equation involving M:</p>	<p>Equation involving M:</p>
<p>16.</p>  <p>(24.)</p>	<p>17.</p>  <p>(25.)</p>
<p>Equation involving M:</p>	<p>Equation involving M:</p>

18. Write equations for a, b, and c below:

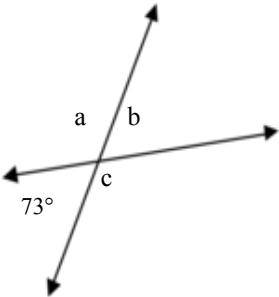

a →

b →

c →



For 19-25 draw a model to help you find the measure of the indicated angle.

19. Find the measure of an angle vertical to a 56° angle.

20. Find the measure of an angle whose supplement is 89° .

21. Find the measure of an angle whose supplement is 9° .

22. Find the measure of an angle whose complement is 28° .

Review: Juan has twice as much money as Lisett, if they have \$180 all together, how much does Juan have?

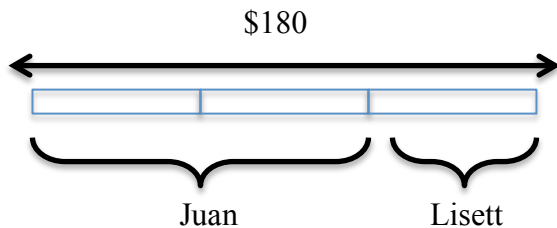

Equation $x + 2x = 180$
 $x = 60$; Juan has \$120

23. Two angles are supplementary; one is two times the measure of the other. What are the measures of the two angles?





24. Two angles are complementary. One angle is 5 times the measure of the other angle. What are the measures of the two angles?

25. One angle is 25° bigger than another angle. The two angles are supplementary. What is the measure of the two angles?

6.1a Homework: Complementary, Supplementary, Vertical, Adjacent Angles

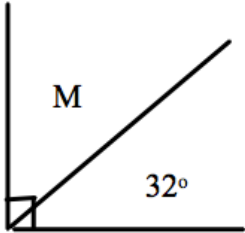
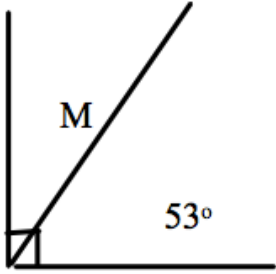
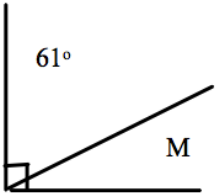
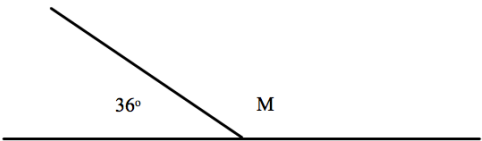
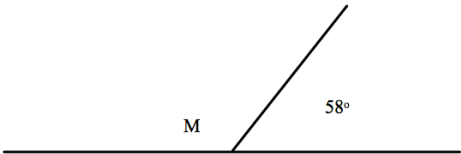
For numbers 1-6, use angle relationship (complementary, supplementary, vertical) to write a simple equation to find the missing angle. Then find the measure of the missing angle.

<p>1.</p>  <p>Equation:</p> <p>M=</p>	<p>2.</p>  <p>Equation:</p> <p>M=</p>
<p>3.</p>  <p>Equation:</p> <p>M=</p>	<p>4.</p>  <p>Equation:</p> <p>M=</p>
<p>5.</p>  <p>Equation:</p> <p>M=</p>	<p>M=</p> 

For each of the following: a) write an equation to find the missing angles and b) find the missing angle.

7. Find the measure of an angle whose complement is 20° .	8. Find the measure of an angle whose supplement is 121° .
9. Two angles are supplementary, and they are equal. What are the measures of the two angles?	10. Two angles are complementary. One angle is 4 times the size of the other angle. What are the measures of the two angles?

Determine if the statement below is *always*, *sometimes* or *never* true. If it is *sometimes* true, give an example when it is true and when it is false. If it is *never* true, give a counter example.

11. Adjacent angles are also supplementary angles.



12. Vertical angles are complementary angles.

13. If one of two adjacent angles is 70° , then the other is also 70° .

14. Vertical angles have the same measure.



15. Perpendicular lines will never intersect.

Spiral Review

1. Solve $-6x + 4 = -2$
2. Simplify the following expression. Use a model if needed.
 $-18m + 8 - 12m$
4. If $\angle A$ is complementary to $\angle F$ and $m\angle A = 79^\circ$, what is $m\angle F$?
4. You can buy 8 apples for \$2.00.
 - a. Find the unit rate for 1 apple.
 - b. Find the unit rate for \$1.

5. Is this graph proportional? _____

How do you know?

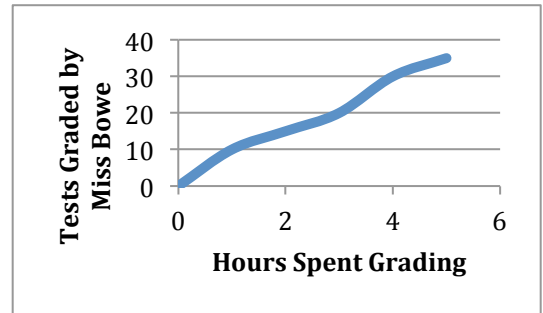

6.1b Class Activity: Angle Pairs and Solving Equations

To begin: Talk in a group about your answers to numbers 11-15 from homework 6.1a. Present your arguments to the class.

Review: Solve each of the equations below:

1. $3x + 1 = x - 5$

3. $13 = 2(x - 1) + 1$

2. $14 = 5 - 3x$

4. $(2x + 3) + (x - 1) = 17$

For each situation below, write an equation and then find the missing angles.

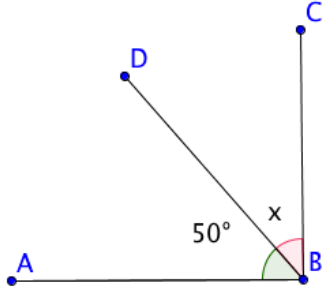
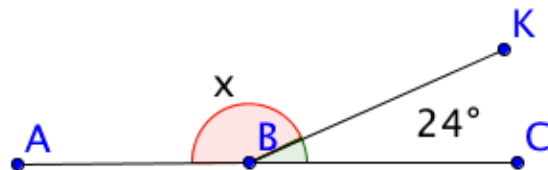
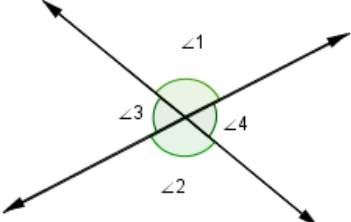
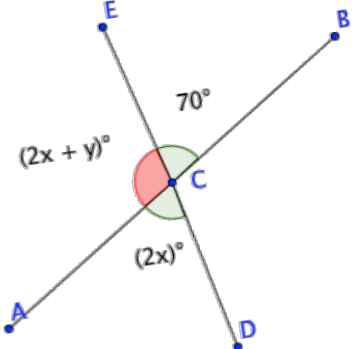
<p>5. Angle ABC is a right angle.</p>  <p>Equation:</p> <p>$x =$ $\angle DBC =$</p>	<p>6. Figure ABC is a straight line.</p>  <p>Equation:</p> <p>$x =$ $\angle ABK =$</p>
<p>7. Given the $m \angle 1 = (3x + 2)$ and the $m \angle 3 = (2x - 7)$.</p>  <p>Equation:</p> <p>$x =$ $\angle 1 =$ $\angle 3 =$ $\angle 2 =$</p> <p>$\angle 4 =$</p>	<p>8. Find the values of x and y in the following figure.</p>  <p>Equation:</p> <p>$x =$ $y =$</p> <p>$\angle ACD =$ $\angle ACE =$ $\angle DCB =$</p>

Write an equation and find the indicated missing angles. Draw a model to show your thinking.

<p>9. A pair of angles are equal. Their sum is 144°. Find the angle measure.</p>	<p>10. Two adjacent angles (A and B) are in the ratio of 4:5. The sum of the angles is equal to 54°. Find the angle measures.</p>
<p>11. $\angle R$ and $\angle W$ are adjacent. $\angle R$ is 30° larger than $\angle W$. Their sum is 70°. Find the angle measures.</p>	<p>12. $\angle A$ and $\angle B$ are supplementary angles whose ratio is 2:3. Find the angle measures.</p>
<p>13. One supplementary angle is 15 degrees less than twice the other. Find the measure of the two supplementary angles.</p>	<p>14. Angles A and B together create a 90° angle. $\angle A = 4x - 10$ and $\angle B = 2x - 20$. Find the angle measures.</p>

Use the diagram to the right for 15 and 16.

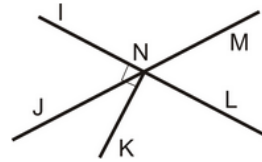

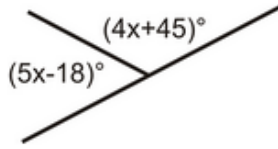
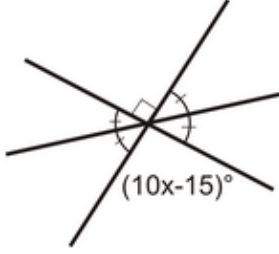
<p>15. Given $\overline{IL} \perp \overline{NK}$.</p> <p>Name two complementary angles:</p> <p>Name two supplementary angles:</p>	<p>16. Given: $m\angle MNL = 70^\circ$. Find the measures of the following angles</p> <p>$m\angle JNK =$</p> <p>$m\angle JNL =$</p> <p>Explain how you arrived at your answer:</p>
<p>17. Find the value of x:</p> 	<p>18. Find the value of x:</p> 

19. Explain how you might check your answer for number 13 and then use the strategy to check your answer

20. Explain how you might check your answer for number 14.

21. Make up a problem like #17 or #18 and solve it. Be prepared to share it with others.

6.1b Homework: Angle Pairs and Solving Equations

Solve each:

1. $4(x - 2) = -24$	2. $\frac{1}{2}(x + 5) = 4$
3. $-3x + 7 - 2x - 1 = 18$	4. $-5 = 3x - 2 - 4x + 1$

Draw a model (where necessary); then write an equation and find the measure of the indicated angle.

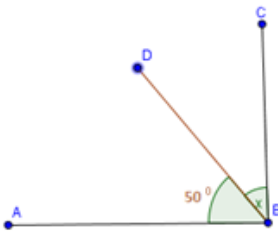
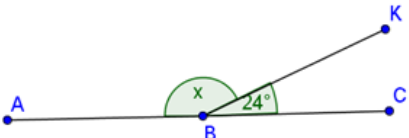
5. A pair of angles are equal. Their sum is 156° . Find the angle measure.	6. Two adjacent angles (A and B) have a ratio of 2:3. The sum of the angles is equal to 80° . Find the angle measures.
7. Angle ABC measures 92° . Find the measure of angle x ? 	8. Figure ABC measures 178° . What is the measure of angle x ? 
9. Angles B and C are adjacent. Angle C is 25° larger than Angle B. Their sum is 80° . Find the angle measures.	10. $\angle A$ and $\angle B$ are supplementary angles whose ratio is 2:7. Find the measures of $\angle A$ and $\angle B$.

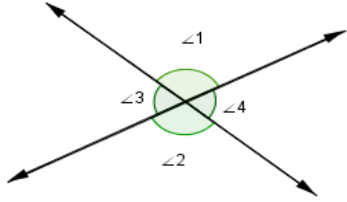
<p>11. One supplementary angle is 12 degrees less than twice the other. Find two supplementary angles.</p>	<p>12. Angles A and B together create a 90° angle. $\angle A = 3x - 2$ and $\angle B = x + 12$. Find the angle measures.</p>
<p>13. Given the $m\angle 1 = 2x + 35$ and the $m\angle 2 = 3x + 7$. Find the angle measures.</p> 	<p>14. Angles 3 and 4 are complementary. The $m\angle 3 = 2y$ and the $m\angle 4 = y - 18$. Find the value of y and find the measure of angles 3 and 4.</p>
<p>15. Two angles are complementary. One of the angles is 34°, what's the measure of the other?</p>	<p>16. Find two supplementary angles such that the measure of the first angle is 30° less than five times the measure of the second.</p>
<p>17. Find two complementary angles such that the measure of the first angle is 40° more than four times the measure of the second.</p>	<p>18. Challenge: If two equal angles are supplements to each other, find the measure of each angle in terms of one variable.</p>

Spiral Review

1. Simplify the following expression. $-4x + 4.5 - 0.94 + 14x$

2. The graph to the left shows how many hours Gabriel worked and how much he was paid. What does the point (1, 15) mean in context of the situation? Use the unit rate in your explanation.

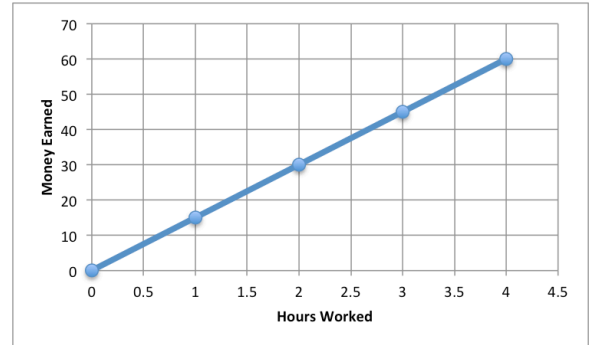

3. Use a proportion to find what 35% of 120 is.

4. If $\angle A$ is vertical to $\angle F$ and $m\angle A = 16^\circ$, what is $m\angle F$

5. Solve $41 = \frac{1}{2}x + (-4)$

6.1c Class Activity: Perimeter and Area with Variables

Review:

1. Find the perimeter and area of the rectangle shown below

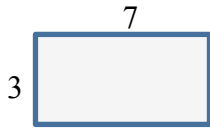

Perimeter:

Area:

2. What is the difference between perimeter and area?

RECALL: if a rectangle's sides are scaled by a factor of 4, then the new rectangle will have a perimeter 3 times the original and an area 16 times the original. Why is this true?

3. Find an expression for the perimeter and area of the rectangle shown below

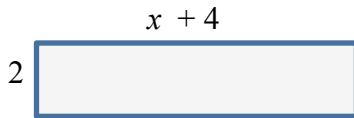

Perimeter:

Area:

If the perimeter is 20, what is the value of x ?

Equation:

Solution:

If the area is 30, what is the value of x ?

Equation:

Solution:

4. Find an expression for the perimeter and area of the rectangle shown below

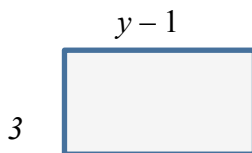

Perimeter:

Area:

Scale this rectangle by a factor of 4. Write an expression for the scaled rectangle's perimeter and area.

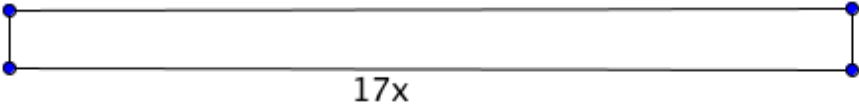

<p>5. The perimeter of a rectangle is 48 in. Its length is twice its width.</p> <p>a. Draw a model of the context.</p> <p>b. Write an equation relating the length and width to the perimeter.</p> <p>c. Solve the equation and state the length and width.</p>	<p>6. The area of a rectangle is 18 in^2. The length is $x + 4$ and the width is 3 in. Draw a model of the context.</p> <p>a. Draw a model of the context.</p> <p>b. Write an equation relating the length and width to the area.</p> <p>c. Solve the equation and state the length and width.</p>
<p>7. A rectangular garden has an area of 48 square feet. One of the sides is currently 6.4 feet while the other is 7.5 feet.</p> <p>a. By how much would the shorter side (the 6.4 foot side) have to be increased to get a garden with an area of 60 square feet? 7</p> <p>b. How much would the longer side (the 7.5 foot side) have to be increase to get the same area (60 square feet)?</p>	<p>8. The area of a rectangular garden is 128 ft^2. On a map of the garden, the scale is $\frac{1}{4} \text{ in.} = 1 \text{ ft.}$ What is the area of the garden on the map?</p>
<p>9. The ratio of length to width of a rectangular photograph is 1:2. The short side is 8 units. If it is reduced by a scale factor of $\frac{1}{3}$, what are the dimensions of the reduced photo, and what is the area of the new photograph?</p>	<p>10. Thirty percent of a photograph is in black ink. In this particular photograph, that means 100 cm^2 is black ink. If the dimensions of the photo are enlarged by a factor of 3, how many square centimeters are black, and what is the area of the enlarged photograph?</p>
<p>11. If the base of the rectangle below is $17x$ and its perimeter is $1 + 34x$, a) what is the length of the vertical sides? b) find x if the area is 50.</p> 	

12. What is the perimeter of the figure to the right?

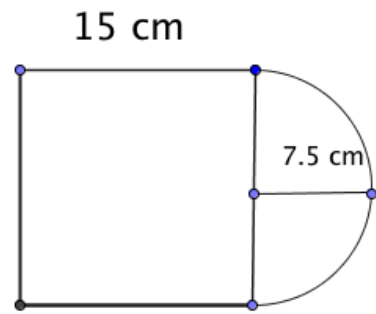

13. What is its area?

14. Find the area of the figure below:

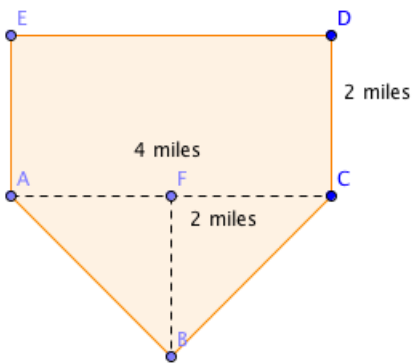

15. The ratio of the length to width of a rectangular photograph is 2:5. The longer side is 15 inches. a) What is the length of the longer side? b) If the area of the photo is quadrupled, what will the new dimensions of the photo be?

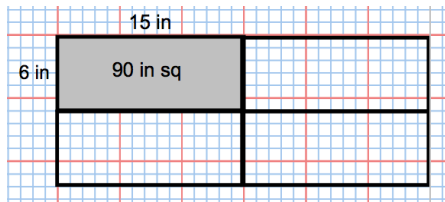

6.1c Homework: Perimeter and Area with Variables

It will be VERY helpful to draw a model of each context.

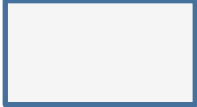
<p>1. Find an expression for the perimeter and area of the rectangle shown below</p> <p style="text-align: center;">$x - 6$</p>  <p>Perimeter = Area =</p> <p>If the perimeter is 60, what is the value of x?</p> <p>If the area is 80, what is the value of x?</p>	<p>2. Find an expression for the perimeter and area of the rectangle shown below</p> <p style="text-align: center;">$x + 21$</p>  <p>Perimeter = Area =</p> <p>If the perimeter is 100, what is the value of x?</p> <p>If the area is 200, what is the value of x?</p>
<p>3. The perimeter of a rectangle is 64 in. Its length is three times its width. Find a) the length and width and b) the area of the rectangle.</p>	<p>4. The area of a rectangle is 28 in^2. The length is $x + 2$ in. and the width is 7 in. Find a) the value of x, b) the length and c) the perimeter of the rectangle.</p>
<p>5. The area of a rectangle is 81 cm^2. The length equals the width. Find a) the length, b) the width, and c) the perimeter.</p>	<p>6. Challenge: What's the biggest area you can enclose with 1000 meters of fencing? Suppose you have a horse and exactly 1000 feet of fencing. You want to create an enclosure for your horse to give it the most area to roam. How would you configure your fence.</p>

7. The area of a rectangular garden is 224 ft^2 . On a map of the garden, the scale is $1 \text{ in.} = 1/2 \text{ ft.}$ What is the area of the garden on the map?
8. The ratio of length to width of a rectangular photograph is 3:5. The shorter side is 3 units. If the dimensions are enlarged by a scale factor of 6, a) what are the dimensions of the enlarged photo? and b) what is the area of the new photograph?
9. 20% of a photograph is in black ink. In this particular photograph, that means 100 cm^2 is black ink. If the area of the photo is enlarged by a factor of 9, a) how many square centimeters are black, and b) what is the area of the enlarged photograph?
10. The perimeter of a square is $4x + 6$. What is its side length.

11. Find the perimeter of the figure to the *right*:

12. Find its area of the figure to the *right*:

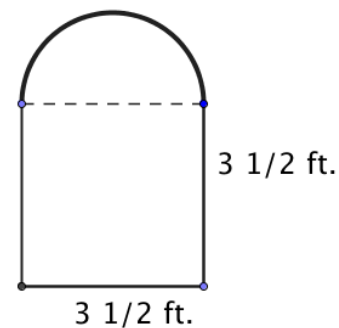

13. Find the area of the figure *below*:

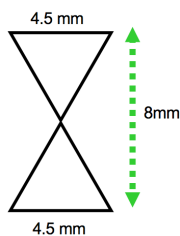

Spiral Review

1. The length of a rectangle is 16 in. longer than the width. Represent the length of the rectangle.

2. What property is shown?

$$8(7 + 2) = 8(2) + 8(7) \underline{\hspace{2cm}}$$

$$18 + 0 = 18 \underline{\hspace{2cm}}$$

3. Determine if the given angles will make a triangle. Explain why or why not.

a. Angles 25° , 60° , 95°

b. Angles 30° , 40° , 20°

4. Add $-4 + -7 =$

5. Solve $6(-1 + 8x) = 18$

6.1d Class Activity: Triangles and Circles

In chapter 5, you worked with angle measures in triangles. Now, you are going to practice writing equations to solve for a missing angle measure. Recall from Chapter 5 that the angles of a triangle sum to 180° .

Example:

Find the missing angle measure:

$$\text{Equation: } 120 + 24 + x = 180$$

$$\text{Solution: } 144 + x = 180$$

$$\begin{array}{r} -144 \quad -144 \\ \hline x = 36^\circ \end{array}$$

$$x = 36^\circ$$

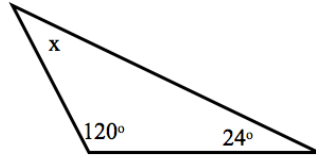

Sometimes, x is not the missing angle measure:

$$\text{Equation: } 2x + 42 + 64 = 180$$

$$\text{Solution: } 2x + 106 = 180$$

$$\begin{array}{r} -106 \quad -106 \\ \hline 2x = 74 \end{array}$$

$$\frac{2x}{2} = \frac{74}{2}$$

$$x = 37$$

$$x = 37$$

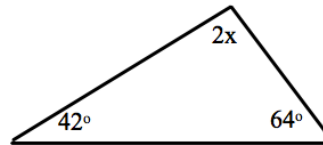

However, x is not the missing angle measure. $2x$ is, so the missing angle measure is $2(37^\circ) = 74^\circ$

Write an equation and solve for x , then find the missing angle measures. *Pictures are not drawn to scale.*

<p>1.</p> <p>Equation:</p> <p>Solution:</p>	<p>2.</p> <p>Equation:</p> <p>Solution:</p>
<p>3.</p> <p>Equation:</p> <p>Solution:</p>	<p>4.</p> <p>Equation:</p> <p>Solution:</p>

<p>5. One angle of a triangle is 5 times the smallest angle. The other angle is 40°.</p> <p>Equation:</p> <p>Solution:</p>	<p>6. The sum of 2 angles of a triangle is $37\frac{1}{2}^\circ$. What is the measure of the other angle?</p> <p>Equation:</p> <p>Solution:</p>
<p>7. The ratio of angles of a triangle is 3:2:1. What are the angle measurements?</p> <p>Equation:</p> <p>Solution:</p>	<p>8. One of the angles of a triangle is one-fourth the size of the largest angle. The other angle is one-half the size of the largest angle. What are the measures of all the angles?</p> <p>Equation:</p> <p>Solution:</p>
<p>9. The ratio of the angles of a triangle is $5:2\frac{2}{3}:1$. What are the measures of all three angles?</p> <p>Equation:</p> <p>Solution:</p>	<p>10. One angle of a triangle is 63°. The ratio of the other two angles is 5:2. What are the measures of all the angles of the triangle?</p> <p>Equation:</p> <p>Solution:</p>
<p>11. The angle of a triangle is 54°. The ratio of the other two angles is 3:5. What are the measurements of all the triangles.</p> <p>Equation:</p> <p>Solution:</p>	<p>12. Two angles of a right triangle have the ratio 5:7. What are the measures of the angles?</p> <p>Equation:</p> <p>Solution:</p>

Now for circles:

Review: What is the formula for the *Circumference* of a circle?

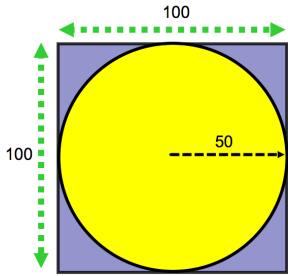

What is the formula for the *Area* of a circle?

13. What if you were only given the circumference? Could you find the radius or diameter?

<p>14. Michael loves swimming. He swam around the edge of a circular pool and found that it took him 176 strokes to swim one complete time around the pool. About how many strokes will it take him to swim across the pool? (Use 3.14 for pi)</p>	<p>15. The circumference of the center circle of a soccer field is 31.416 yards. What is the radius of the circle? Equation: Solution:</p>
<p>16. Find the radius of a circle with a circumference of 22 feet. Equation: Solution:</p>	<p>17. A farmer has a 100 feet x 100 feet plot of land he needs to water. He has a sprinkler that waters in a circle. The sprinkler has a reach of 50 feet. If he puts the sprinkler in the center of the plot of land, what <i>percent</i> of the plot will be watered? (Hint: Draw a picture first)</p>
<p>18. Pizzas are sold according to diameter. For example, a 6 inch pizza is a pizza with a diameter of 6 inches. At Francesco's pizzeria, there are two pizzas. Pizza A is a 12 inch, and Pizza B has an area of 450 in^2. Which pizza is bigger? What is the percent of increase from the smaller pizza to the larger pizza?</p>	 <p>The diagram shows a square plot of land with side length 100 feet. A yellow circle representing the area watered by a sprinkler is centered in the square. The radius of the circle is labeled as 50 feet. Dashed green lines indicate the 100-foot dimensions of the square plot.</p>
<p>19. A bike's wheel diameter is 50 cm. If the wheel rotates 45 times a minute, how far has the bike traveled after 30 minutes?</p>	<p>20. Mary has a circular table whose diameter is 7 feet. She would like to put a tablecloth on it, but the packaging only gives the area. The tablecloth she bought says it is 110 ft^2. Will the tablecloth fit?</p>

6.1d Homework: Triangles and Circles

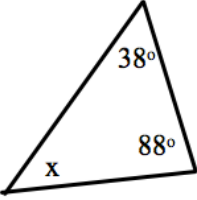
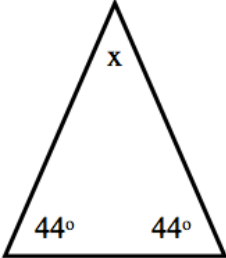
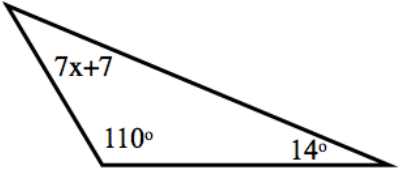
Write an equation to find x , then find the measure of the missing angle. *Pictures are not drawn to scale.*

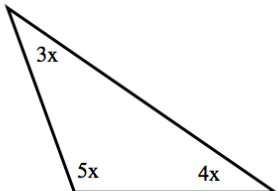
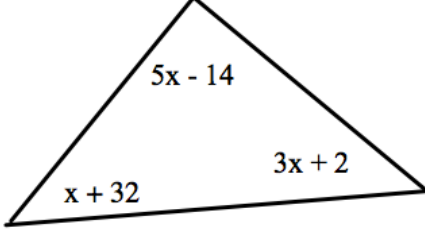
<p>1.</p>  <p>Equation:</p> <p>Solution:</p>	<p>2.</p>  <p>Equation:</p> <p>Solution:</p>
<p>3.</p>  <p>Equation:</p> <p>Solution:</p>	<p>4.</p>  <p>Equation:</p> <p>Solution:</p>
<p>5.</p>  <p>Equation:</p> <p>Solution:</p>	<p>6.</p>  <p>Equation:</p> <p>Solution:</p>

<p>7. One angle of a triangle is 3 times the smallest angle. The third angle is 60°.</p> <p>Equation:</p> <p>Solution:</p>	<p>8. The sum of 2 angles of a triangle is $39\frac{1}{4}^\circ$. What is the measure of the other angle?</p> <p>Equation: $180 - 39\frac{1}{4} = x$</p> <p>Solution:</p>
<p>9. One angle of a triangle has a measure of x. Another angle is $3\frac{1}{2}$ times the size of angle x. The third angle is half the size of angle x. What are the measures of all three angles?</p> <p>Equation:</p> <p>Solution:</p>	<p>10. One of the angles of a triangle is three-fourths the size of the largest angle. The other angle is one-half the size of the largest angle. What are the measures of all the angles?</p> <p>Equation:</p> <p>Solution:</p>
<p>11. The ratio of angles of a triangle is 3:1:1. What are the angle measurements?</p> <p>Equation:</p> <p>Solution:</p>	<p>12. One angle of a triangle is 80°. The ratio of the other two angles is 3:2. What are the measures of all the angles of the triangle?</p> <p>Equation:</p> <p>Solution:</p>
<p>13. The angle of a triangle is 52°. The ratio of the other two angles is 3:4. What are the measurements of all the triangles.</p> <p>Equation:</p> <p>Solution:</p>	<p>14. Two angles of a right triangle have the ratio 2:3. What are the measures of the angles?</p> <p>Equation:</p> <p>Solution:</p>

<p>15. Phil has a lamp with a circular base that he would like to fit onto a circular side table in his house. The area of the base of the lamp is 70 in^2. The table has a radius of 5 in. Will the lamp fit? Be sure to show all your work.</p>	<p>16. The circumference of a pizza is 81 in. What is the radius?</p>
<p>17. The circumference of a circular hot tub cover is 200 ft. What is the area of the cover?</p>	<p>18. The circumference of a basketball hoop is 125.6 in. What is the area inside the hoop?</p>
<p>19. A pizza place charges \$12 for a 12 inch pizza, \$14 for a 14 inch pizza, \$16 for a 16 inch pizza, and \$20 for a 20 inch pizza. Which pizza is the best deal? Justify your response.</p>	

Spiral Review

1. Luis went to a soccer game with some friends. He bought two sodas for \$1.50 each and four giant candy bars for \$2.25 each. Write a numeric expression showing how much he spent. Then calculate the total he spent.
2. Use long division to show how you can convert this fraction to a decimal and then a percent
 $\frac{2}{7}$
3. Solve: $\frac{3}{4}x - \frac{7}{8} = \frac{5}{8}$
4. Simplify: $x + 3x - 7x + 2x^2$
5. Write a context for the following expression: $4(x - 3)$

6.1e Self-Assessment: Section 6.1

Consider the following skills/concepts. Rate your comfort level with each skill/concept by checking the box that best describes your progress in mastering each skill/concept. Sample problems can be found on the following page.

Skill/Concept	Beginning Understanding	Developing Skill and Understanding	Practical Skill and Understanding	Deep Understanding, Skill Mastery
1. Use properties of supplementary, complementary, vertical, and adjacent angles to solve for unknown angles in figures.	I know what the properties of supplementary, complementary, vertical, and adjacent angles are, but I struggle to use them to solve for unknown angles.	With some help, I can find an unknown using properties of supplementary, complementary, vertical, and adjacent angles.	I can find an unknown angle using properties of supplementary, complementary, vertical, and adjacent angles.	I can find an unknown angle using properties of supplementary, complementary, vertical, and adjacent angles by drawing a diagram or writing an equation. I can justify my procedures and explain how to find other missing angles in the same context.
2. Write and solve equations based on a diagram of intersecting lines with some known angle measures.	I struggle to write an equation based on a diagram of intersecting lines.	With help I can write and solve an equation based on a diagram of intersecting lines.	I can write and solve an equation based on a diagram of intersecting lines with some numeric angle measures OR with angle measures given as algebraic expressions.	I can write and solve an equation based on a diagram of intersecting lines with some numeric angle measures OR with angle measures given as algebraic expressions. I can also justify all my procedures.
3. Write and solve equations based on area and perimeter.	I struggle to write an equation based on area or perimeter.	With help, I can write an equation based on area or perimeter.	I can write and solve an equation based on area or perimeter with a numeric side length OR written as algebraic expressions.	I can write and solve an equation based on area or perimeter with a numeric side length OR written as algebraic expressions. I can also justify my procedures.
4. Find the measure of missing angles in a triangle.	I know what the property of angle measures in a triangle, but I struggle to use it to solve for unknown angles.	With help I can solve for missing angles in a triangle.	I can solve for unknown angles in a triangle.	I can solve for unknown angles in a triangle. I can explain why my procedure works.
5. Find the measure of missing lengths of a circle.	I know algorithms for circumference of a circle, but I struggle to use them to solve for missing lengths of a circle.	I can usually write and solve an equation based on a circle to find missing lengths of a circle.	I can write and solve an equation based on the circumference of a circle.	I can write and solve an equation based on the circumference or the area of a circle. I can also explain the relationship between circumference and area.

Sample Problems for Section 6.1

1. Find the measure of the missing angle.

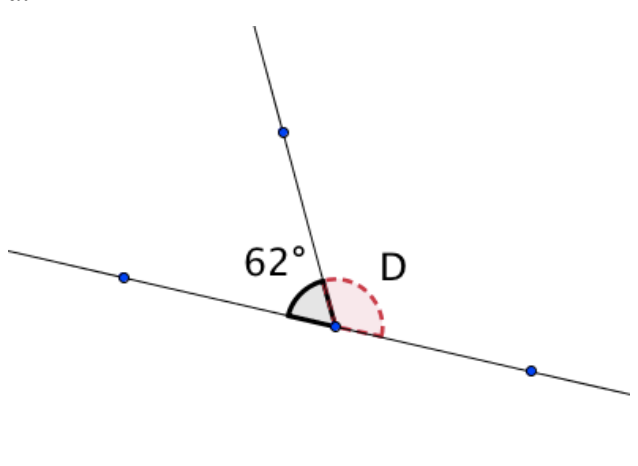
<p>a.</p> 	<p>b. Find the measure of an angle vertical to a 94° angle.</p>
<p>c. Find the measure of an angle whose complement is 48.4°.</p>	<p>d. Two angles are complementary. One angle is 4 times the measure of the other angle. What are the measures of the two angles?</p>

2. Find the measure of the missing angles in each diagram by first writing an equation:

a.

Angle	$\angle EHD$	$\angle GHD$	$\angle FHG$
Measure			

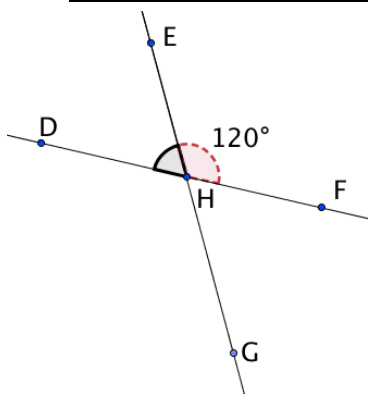

b.

Angle	$\angle JOP$	$\angle MOK$	$\angle MON$
Measure			

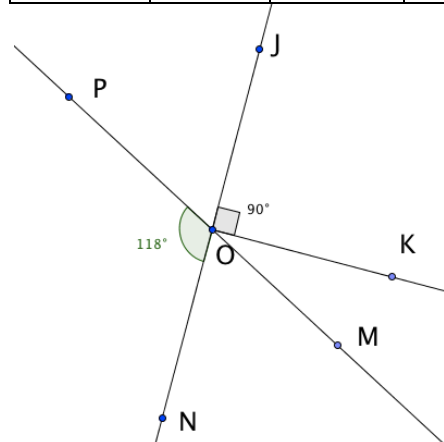

3. Write an equation to solve the following problems.
- a. Terry is building planter boxes for his garden. He wants each box to have an area of 12.5 ft^2 . If each box is 5 feet wide, how long should he make them?

- b. If the perimeter of rectangle to the right is 144, what is the value of t ?

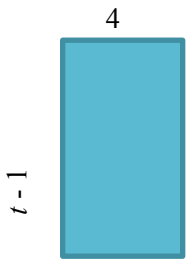

- c. If the area of the rectangle to the right is 52, what is the value of t ?

4. Find the missing angles in each triangle drawn or described below.

a.

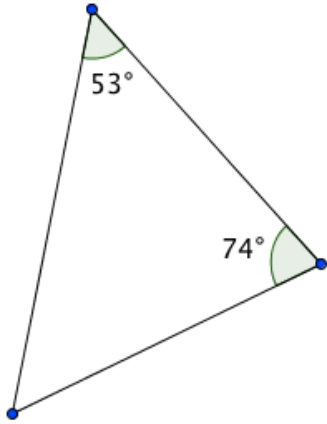

- b. A triangle has the following angles: 37° and 53° . What is the measure of the third angle?

- c. One angle in a triangle is 90° . The ratio of the other two angles is 1:8. What is the measure of each angle?

d.

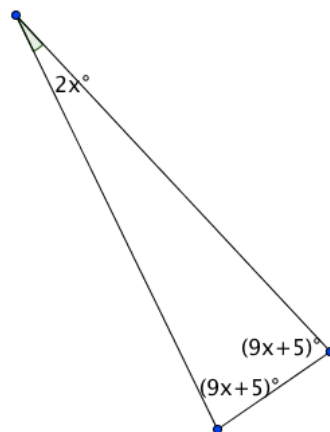

5. Write an equation to solve the following problems involving circles:
- The circumference of Fabian's watch is 125.6 mm. What is the diameter of his watch?
 - General Sherman is a giant sequoia tree in California. The largest in the world, its circumference is 102.6 feet. What is its diameter?
 - The circumference of a carousel is 21.98 yd. What is the area of ground covered by the carousel?
 - Everlie buys a take-and-bake pizza. The area of the pizza is 154 in^2 . Her pizza pan to bake it on has a 16 in. diameter. Will the pizza fit on her pan?

Section 6.2 Write and Solve Equations from Word Problems

Section Overview:

This section begins with a review of solving multi-step equations, both with and without models, within a context. Students then build on that understanding to work with more complicated situations. Activities in this section have students working in two “different directions”—in some sections students will be given a context and asked to find relationships and solutions, while in other sections, students will be given relationships and asked to write contexts. The goal is to help students understand the structure of context in relationship to algebraic representations.

Concepts and Skills to be Mastered

By the end of this section, students should be able to:

1. Recognize and explain the meaning of a given expression or equation and its component parts.
2. Solve multi-step context problems involving calculations with positive and negative rational numbers in a variety of forms.
3. Use variables to create equations that model word problems.
4. Solve word problems leading to linear equations.

Anchor Problem: Cookies for a Party

I go to the store to buy cookies, milk, napkins, and cups for a party. I need to know how many packages of cookies I can buy and still have money left over. I have \$35.50 in my wallet. I know that I need 2 packages of napkins at \$1.50 each and two packages of cups at \$3.50 each. I need one gallon of milk for every two packages of cookies. Each gallon of milk costs \$2.50. Each package of cookies costs \$3. How many packages of cookies can I buy and still have money left over?

6.2a Class Activity and Homework: Write and Solve Equations for Word Problems I

In the exercises below you are given either a context/word problem OR a model/equation. Provide the missing information. Solve each problem. An example is given.

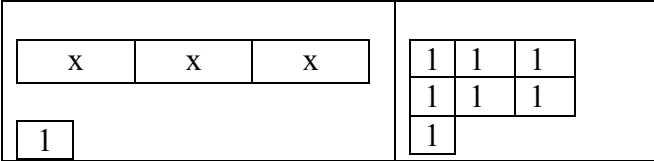
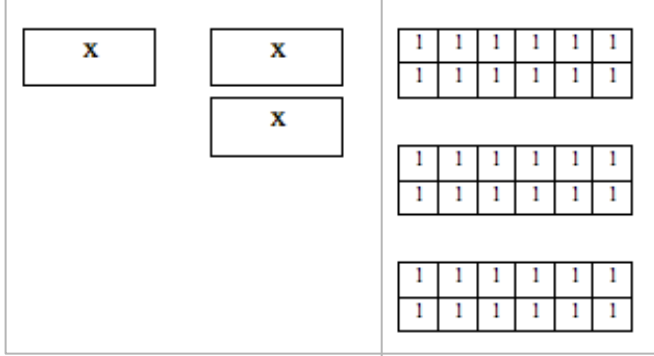
Word Problem	Model and/or equation	Solution
<p>EXAMPLE Three times some number plus one is seven. What is the number?</p>	 $3x + 1 = 7$	$x = 2$
<p>1.</p>	$4x + 2 = 30$	
<p>2. Eleven less than 5 times a number is 24.</p>		
<p>3. The quotient of a number and -9 is increased by 10 the result is 11.</p>		
<p>4.</p>	 $x + 2x = 36$	

5.	$-3x - 5 = -2$	
6.	$m - 26 = 15$	

For the next set of exercises, write contexts that are more “real life”.

<p>Example: For two months in a row I made the same amount babysitting. I deposited my babysitting money into my savings account that had \$80, I now have \$350 in my account. How much money did I make each month babysitting?</p>	$2x + 80 = 350$	
---	-----------------	--

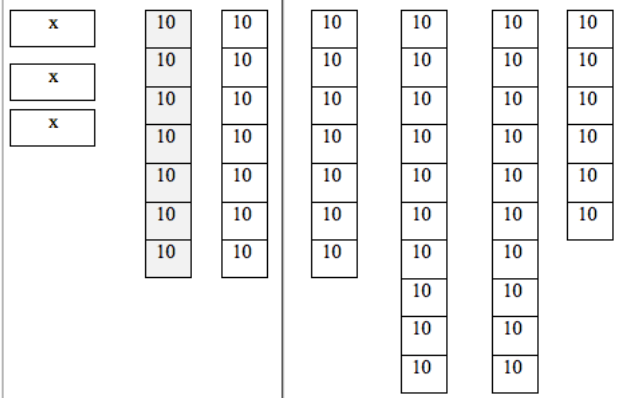
7.	 <p style="text-align: center;">$3x - 70 = 260$</p>	
----	---	--

8.	$x/2 - 5 = 10$	
----	----------------	--

9.	$(2/3)x - 20 = 280$	
----	---------------------	--

10.

$$3x + 2x = 85$$

11.

$$x + (x+3) + x + (x+3) = 34$$

12.

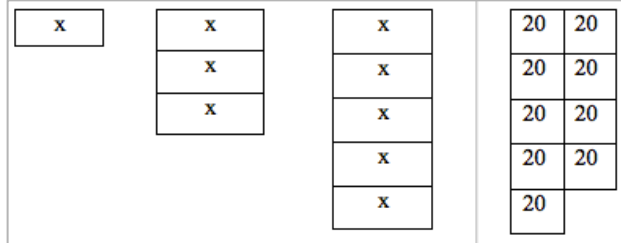

$$x + 3x + 5x = 180$$

$$(2/5)x + (1/5)x = 360$$

13.

14.

$$0.2x + x = 240$$

Spiral Review

1. Write an expression to model the following situation in two different ways: The price of the car was reduced by 15%.
2. Juliana bought 3 bags of chips and 3 sodas for herself and two friends. The chips were \$0.85 a bag. Write an equation to find the price of each can of soda if she spent a total of \$6, then solve.
3. Simplify the following expression.
$$71b - 4a + 4b - 4a$$
4. Solve: $7 = 3x - 2$
5. Write a context for the following expression: $26 + 8x$

6.2b Class Activity and Homework: Write Word Problems for Equations I

Working backwards, writing the word problems for the equations. The first one is done for you.

Given Information & Equation	Write a word problem to go with the information and the equation to the left.	Solve the equation. Then figure out all missing information.
1. Given information: <ul style="list-style-type: none"> • a = Ali's age now • $2a - 3$ = Mel's age now Equation: $a + 2a - 3 = 39$ years	The sum of Ali and Mel's age is 39. If Mel is 3 years younger than twice Ali's age, how old are Ali and Mel?	$a = 14$ Ali is 14 and Mel is 25
2. Given information: <ul style="list-style-type: none"> • s = small angle • $4s$ = larger angle Equation: $s + 4s = 70$ degrees		
3. Given information: <ul style="list-style-type: none"> • w = width of rectangle • $2w + 3$ = length of rectangle Equation: $w + 2w + 3 + w + 2w + 3 = 78$ in.		
4. Given information: <ul style="list-style-type: none"> • v = Vicki's money • $5v$ = Wally's money Equation: $5v + v = \$72$		

<p>5. Given information:</p> <ul style="list-style-type: none"> • $2m$ = Number of red marbles • $3m$ = Number of blue marbles <p>Equation: $2m + 3m = 155$ marbles.</p>		
<p>6. Given information:</p> <ul style="list-style-type: none"> • e = Elisabeth's age now • $e - 7$ = Zack's age now • $e + 4$ = Gail's age now • $2e$ = Bob's age now <p>Equation: $e + (e - 7) + (e + 4) + 2e = 82$</p>		
<p>7. Given information:</p> <ul style="list-style-type: none"> • a = Measure of angle A • $a + 20$ = Measure of angle B • $a - 10$ = Measure of angle C <p>Equation: $a + a + 20 + a - 10 = 180^\circ$.</p>		
<p>8. Given information:</p> <ul style="list-style-type: none"> • c = cost of a shirt • $.25c$ = 25% of the cost of the shirt <p>Equation: $c - 0.25c = \\$28.80$</p>		

<p>9. Given information:</p> <ul style="list-style-type: none"> • m = height of a maple tree • $0.15m$ = 15% of the height of the maple tree <p>Equation: $m + 0.15m = 97.75$ feet</p>		
<p>10. Given information:</p> <ul style="list-style-type: none"> • z = length of a side of a triangle • $2z$ = length 2nd side of a triangle • $2z + 3$ = length of 3rd side of triangle <p>Equation: $z + 2z + (2z + 3) = 73$ cm.</p>		
<p>11. Given information:</p> <ul style="list-style-type: none"> • s = the price of a pair of socks • $5s - 1$ = the price of a pair of shoes <p>Equation: $3s + 2(5s - 1) = \\$56.50$</p>		
<p>12. Given information:</p> <ul style="list-style-type: none"> • g = Gordon's allowance • $2g - 1$ = Chris's allowance • $0.5g$ = Drew's allowance <p>Equation: $g + 2g - 1 + 0.5g = \\$51.50$</p>		

<p>13. Given information:</p> <ul style="list-style-type: none"> • x = length of blue ribbon • $2x + 3$ = length of red ribbon • $3x - 1$ = length of green ribbon <p>Equation: $x + 2x + 3 + 3x - 1 = 92$ inches</p>		
<p>14. Given information:</p> <ul style="list-style-type: none"> • x = Amount of money Jaime earned • $(1/5)x$ = one-fifth of the money Jaime made. • $(2/5)x$ = two-fifths of the money Jaime made. <p>Equation: $(1/5)x + (2/5)x = \\$165$</p>		

Spiral Review

1. Solve:

a. $-14 = 3x - 2$

b. $-8 = -3m + 10$

2. Write an expression to represent the following situation. Danielle is having a birthday party and inviting 8 friends. She wants to give each friend a gift bag with a large candy bar and a notebook. Show the total price if each large candy bar costs \$1.40.

3. Use the distributive property to rewrite the following expression $-4(5x - 1)$

4. Express each percent as a fraction in simplest form.

44%

17.5%

5. Malory got a 75% on her math test. To earn that score, she got 27 questions correct. Write an equation to find how many questions were on the test. Then solve.

6.2c Class Activity: Write and Solve Equations for Word Problems II

1. Matt, Rosa, and Kathy are cousins. If you combine their ages, they would be 40 yrs. old. Matt is one-third of Rosa's age. Kathy is five years older than Rosa. How old are they? Show several ways to solve the problem. Be able to explain how you came to your answer.
- a. If necessary, use a model to help you write an equations for this context.

Rosa	Matt is $\frac{1}{3}$ Rosa's age so Matt is	Kathy is five years older than Rosa so Kathy is
Write an equation for the sum of the cousin's ages: Find x		

- b. How old is Rosa?
- c. How old is Matt?
- d. How old is Kathy?
- e. How can you be sure you have the correct answer?
2. The senior class has 412 students. They are assigned to different homerooms. There are 28 students in the smallest home room and the remaining 12 homerooms have the same number of students. How many students are in each of the remaining 12 homerooms?
- a. If necessary, use a model to help you write an equations for this context.
- b. How many students are in each of the 12 remaining homerooms?
- c. How do you know your answer is correct?

3. Billy is three years older than his sister Anne. Together, the sum of their ages is 25. How old are Billy and Anne?
- Write an equation for this context. Use a model to help you if necessary.
 - How old is Billy?
 - How old is Anne?
 - Show that your answer is correct.
4. At the store, you find a pair of jeans and a t-shirt. Together, they'll cost \$80.20. The jeans cost three times the cost of the t-shirt. How much does each cost?
- Use a model to help you write an equation for this context.
 - How much do the jeans cost?
 - How much does the t-shirt cost?
 - How do you know your answer is correct?

5. The sum of two numbers is 41. The larger number is 1 more than 5 times the smaller number. What are the two numbers?
- Use a model to help you write an equation for this context.
 - What are the two numbers?
 - How do you know your answer is correct?
6. The sum of three consecutive integers is 21. What are the numbers?
- Use a model to help you write an equation for this context.
 - What are the three numbers?
 - How do you know your answer is correct?

6.2c Homework: Write and Solve Equations for Word Problems II.

Write equations for the sentences below. Then solve. If needed, draw a model.

<p>1. Fifteen more than twice a number is -23. Equation: Solution:</p>	<p>2. The sum of three times a number and -23 is 28. Equation: Solution:</p>	<p>3. The difference between 5 times a number and 4 is 16. Equation: Solution:</p>
<p>4. Nine more than -8 times a number is -7. Equation: Solution:</p>	<p>5. The difference between 12 and ten times a number is -28. Equation: Solution:</p>	<p>6. Seven more than three times a number is 52. Equation: Solution:</p>
<p>7. Eleven less than five times a number is 19. Equation: Solution:</p>	<p>8. Thirteen more than four times a number is -91. Equation: Solution:</p>	<p>9. Seven less than twice a number is 43. Equation: Solution:</p>

Write equations for the word problems below. Then solve. If necessary, draw a model.

10. The total cost of a suit and 4 ties is \$292. The suit cost \$200. The ties are all the same price. What is the cost of a tie?

Equation:

Solution:

11. Mary's sister is 7 years older than Mary. Their combined ages add up to 35. How old is Mary?

Equation:

Solution:

12. If Cassandra had 8 more dollars, she could buy the \$40 pair of hiking boots she wants. How much money does Cassandra have?

Equation:

Solution:

13. Tammy is training for a marathon. She ran the 3 miles from home to a lake, twice around the lake and then home again. She ran 11 miles. How far is it around the lake?

Equation:

Solution:

Spiral Review

1. Solve $4(x+1)+4x=36$
2. Phoebe has \$10. Write an expression showing how much money she will have left after buying 3 candy bars and a pack of pencils.
3. Simplify $-2(x+1)-x+5$
4. Find each sum without a model.
 - a. $-27.2 + \frac{4}{5}$
 - b. $98.1 + (-1.35)$
5. I go to a department store with a coupon for 20% off any one item. The shoes that I want are on sale for 40% off. Write and solve an equation to find the original price if I paid \$48.

6.2d Class Activity: Write and Solve Equations from Word Problems III

Do the following four things for each problem:

- Write the equation as complete as possible to include all the information.
- Solve the equation.
- Answer the question(s) in complete sentences.
- Check. Does your answer(s) make sense? Why?

1. For a field trip, 331 students went to the museum. Most of the students rode on the 6 buses provided by the school, but 7 students traveled in cars. If the same number of students road each bus, how many students were in each bus?	
a.	c.
b.	d.

2. Ivan was broke (as usual!) Then he got his weekly allowance, but because he has a hard time saving money, he spent half his weekly allowance playing mini-golf. He then earned 4 dollars cleaning out his parents' car. If he now has \$12, how much is his weekly allowance?	
a.	c.
b.	d.

3. The cooking club made some pies to sell to raise money for new math books. The cafeteria contributed four pies to those made by the club. All of the pies were then cut into five pieces each and sold by the piece. There were a total of 60 pieces to sell. How many pies did the club make?	
a.	c.
b.	d.

4. Jan bought 2 shirts (same style and cost but different colors) and 2 pair of pants (same style and cost but different colors). Each shirt was \$3 less than a pair of pants. She spent \$49.80 (before tax). What is the price of a shirt? What is the price of a pair of pants?

a.	c.
b.	d.

5. Tom was training for a marathon. During the first week he ran a certain distance. The second week he ran 1.5 times further than the first week. During the third and fourth weeks, he ran 3 miles more than twice what he ran the first week. He ran a total of 136 miles in those four weeks. How many miles did he run each week?

a.	c.
b.	d.

6. Cassie and Tom wanted hamburgers for lunch. Cassie ordered a hamburger for \$4 and an order of fries. Tom ordered twice Cassie's order. The total price was \$16.65 (before tax). What is the cost of one order of fries?

a.	c.
b.	d.

7. Lupe and Carlos work in an office. Carlos makes \$16,000 less than twice Lupe's salary. The sum of their two salaries is \$104,000. How much are their salaries?

a.	c.
b.	d.

8. The neighborhood candy store sold 336 candy items this week. Twice as many M&Ms were sold as Snickers, and three times as many Crunch bars were sold as Snickers bars. How many of each kind of candy were sold this week?	
a.	c.
b.	d.

9. Paul and Ringo went to the music store. Paul bought some guitar picks for \$6 and a package of guitar string. Ringo bought some new drumsticks for \$8. Then Paul remembered he had a coupon for \$5 off. The final bill after the coupon was \$15. How much was the package of guitar string?	
a.	c.
b.	d.

10. Steve, Tyrel, and Josh spent a total of \$20 at the soccer game. It costs \$3 for each one of them get into the game. Each boy also bought a program. Josh bought a foam hand to wave in the bleachers. The foam hand was \$5. What is the cost of one program?	
a.	c.
b.	d.

11. A total of 960 students attend Bosco Middle School. Some students walk to school, some ride the bus, and the rest come by car. The ratio of bus-riders to walkers to car riders is 6:3:1. How many students come to school by each form of transportation?	
a.	c.
b.	d.

12. Mr. Manycattle drove to Mexican Hat, Utah from southern New Mexico in 4 days. On Monday and Wednesday, he traveled exactly the same distance. On Tuesday, he traveled 2 times as far as he did on Monday, and on Thursday, he traveled 3 times as far as he did on Monday. If the total trip covered 602 miles, how far did Mr. Manycattle travel each day of his trip? Which fraction describes the part of the trip covered on each day?

a.	c.
b.	d.

13. Ana had \$60 to spend at the mall. She bought 2 shirts for \$12.99 each, and 3 pounds of candy for \$2.89 per pound. How much money does she have left?

a.	c.
b.	d.

6.2d Homework: Write and Solve Equations from Word Problems III

For each context: a) write an equation, b) solve your equation, c) answer the question in a complete sentence, and d) check your answer. You may need to do your work on a separate sheet of paper.

1. Allie had \$24. After buying seven art pencils and a \$0.35 eraser, she had \$10 left. How much did each pencil cost?
2. Sarah won 40 super bouncy balls playing horseshoes at her school's game night. Later, she gave two each to some of her friends. If she has 8 remaining bouncy balls, to how many friends did she give bouncy balls?
3. At the local clothing store all shirts were on sale for one price and sweaters for a different price. Lonnie purchased three sweaters and two shirts for \$130. If the sale price of a shirt was five dollars less than the sale price of a sweater, how much did each item cost Lonnie?
4. Brock ate 16 Girl Scout cookies in 5 days (he wasn't suppose to eat any cookies because they belonged to his sister.) The second day he ate 3 more than the first (he felt pretty bad about that.) The third day he ate half as much as the 1st day (he was able to get better control of himself.) The fourth and fifth days, he ate twice each day what he ate the first day (he really likes Girl Scout cookies.) How many cookies did he eat each day?

5. Cassie and Tom went to the hamburger stand. Cassie ordered a hamburger for \$4 and an order of fries. Tom was really hungry, so he doubled Cassie's ordered for himself. The total price was \$18 (before tax). What's the cost of one order of fries?

6. A collection of marbles has been divided into 3 different sets. The middle sized set is 2 times the size of the smallest set, and the largest set is 3 times as large as the middle-sized set. What fraction describes each part of the total marble collection?

7. Challenge: Brian buys 1 pack of baseball cards to add to the 2 cards a friend gave him. Then his mother gives him 2 more packs as a special treat. Now he has as many cards as Marcus who owns 1 pack plus 12 loose cards. How many cards are in each pack?

Spiral Review

1. Zach invested \$1500. If he earned 23.2% on his investment, a) write a proportion to find the amount of money he earned and b) state how much money he now has.

2. Use the number line below to show why $(-1)(-1) = 1$

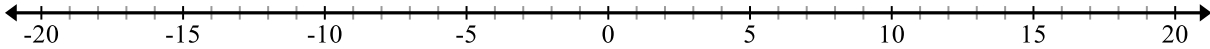

3. If the ratio of girls to boys in a class is 3 to 4 and there are 35 students in the class. How many students are girls?
4. Lin is drawing a scale model of his school. He uses a scale of 1 in = 5 feet. If his classroom is 30 feet by 25 feet, what will be the dimension of the classroom on his scale model?
5. The equation $p = 6h$ shows how many pies *Pi Tree Bakery* sells on a given day. What is the unit rate?

6.2e Extra Practice: Write and Solve Equations

<p>1. You bought a magazine for \$5 and four erasers. You spent a total of \$15. How much did each eraser cost?</p>	<p>2. Old McDonald's 3 hens each lay the same number of eggs one week. This gives Old McDonald's wife enough eggs to make two recipes. One recipe requires 10 eggs and the other recipe requires 2 eggs. How many eggs did each hen lay?</p>
<p>3. Paul owns a set of model cars. His brother gives him 3 more sets for his birthday. Then Paul gives 1 set to a friend who really likes model cars but doesn't have any. Now Paul has 30 model cars left. How many model cars are in each set?</p>	<p>4. Tanner likes to collect comic books. He has 3 sets of the same title comics and 5 other comic books. His friend, Scott, has 1 set (the same as Tanner's) and 19 other comic books. The total number of comic books owned by Tanner and Scott is the same. How many books are in each set?</p>
<p>5. Erin can buy 5 Putt-putt tickets and 2 one-dollar boxes of popcorn for the same price as 3 putt-putt tickets and 12 one-dollar boxes of popcorn. How much does each putt-putt ticket cost?</p>	<p>6. Allison has 2 aquariums. In each aquarium she has 2 families of guppies and 3 tetras. Leigh has 1 aquarium with 10 tetras and 3 families of guppies. Allison and Leigh have the same number of fish and their guppy families each have the same number of members. How many guppies are in each family?</p>

<p>7. A whole object has been broken into 4 pieces, all of different sizes. Each piece is 2 times the size of the next smallest piece. What fractions describe each piece of the whole object?</p>	<p>8. Mrs. Smith rode the bus 720 miles in 3 days. On the first day, she traveled 3 times as far as she did on the second day. On the third day, she traveled 2 times as far as she did on the second day. How far did she travel each day?</p>
<p>9. The neighborhood grocery store sold 1463 bottles of soft drinks last month. Twice as many bottles of root beer were sold than lemon-lime soda, and twice as many bottles of cola were sold than root beer. How many bottles of each type of soft drink were sold?</p>	<p>10. Jill runs 5 miles to get to work. After work, she runs home, to a restaurant, and then back home again. In total, she runs 14 miles that day. How many miles is it from the restaurant to her house?</p>

6.2f Self-Assessment: Section 6.2

Consider the following skills/concepts. Rate your comfort level with each skill/concept by checking the box that best describes your progress in mastering each skill/concept. Sample problems can be found on the following page.

Skill/Concept	Beginning Understanding	Developing Skill and Understanding	Practical Skill and Understanding	Deep Understanding, Skill Mastery
1. Create an algebraic expression or equation to model a context.	I struggle to begin writing an algebraic expression or equation that models a context.	I can draw a model that represents a context. I struggle to use that model to create an algebraic equation.	I can write an algebraic equation that represents a context if I draw a model first.	I can write an equation that models a word problem.
2. Create a context that models an algebraic expression or equation.	I struggle to begin writing a context that models an algebraic expression or equation.	I can write a numeric context that models an algebraic expression or equation.	I can create a numeric or real-life context that models an algebraic expression or equation.	I can create a real-life context that models an algebraic expression or equation. I can verify that the answer is reasonable in that context.
3. Solve multi-step real-life problems involving calculations with positive and negative rational numbers in a variety of forms.	I can solve one and two-step real-life problems, but I struggle to solve multi-step real-life problems.	I can solve multi-step real-life problems involving calculations with integers with an equation by first drawing a model.	I can solve multi-step real-life problems involving calculations with integers with an equation without a model.	I can solve multi-step real-life problems involving calculations with rational numbers.
4. Determine the reasonableness of an answer to a contextual problem.	I struggle to determine the reasonableness of an answer to a contextual problem.	I can determine if the answer to a contextual problem is reasonable, but I struggle to explain why.	I can determine if the answer to a contextual problem is reasonable, and I can to explain why.	I can determine if the answer to a contextual problem is reasonable, and I can to explain why. If it is not reasonable, I can rethink that problem to find a reasonable answer.

Sample Problems for Section 6.2

1. Write an equation for each context. Draw a model first if necessary.
 - a. Tom has \$12,484 in his bank account. Six months ago, he had \$1,240. How much does Tom get paid each month if he has only deposited his monthly paycheck into his account?

 - b. Sixty-five pounds of candy was divided into four different boxes. The second box contained twice the amount of the first box. The third box contained two more pounds than the first box. The last box contained one-fourth the amount in the second box. How much candy was in each box?

 - c. Simon is ordering equipment for his tennis team. He orders a racquet and can of three tennis balls for each player. Each can of balls costs \$4. For a team of 5 players, his bill total is \$415. How much does each racquet cost?

2. Write a context that models the following equations. At least one context should be real-life.

$$2L + 2(3L) = 990$$

$$3m + 4(m - 0.50) = 12$$

$$-46 = 6x + 2$$

3. Solve the following real-life problems.
- The sum of two numbers is 52. One number is three less than quadruple the other number. What are the two numbers?
 - Martha divides \$94 amongst her four friends. Leon gets twice as much money as Kokyangwuti. Jill gets five more dollars than Leon. Isaac gets ten less dollars than Kokyangwuti. How much money does each friend get?
 - Elizabeth has \$26 left after shopping at the mall. She bought 2 shirts for \$22.99 each, a drink for \$2.02, and 2 books for \$16 each. How much money did she start with?
4. For each of the contexts in problem 3, answer the following questions:
- Is the answer reasonable or not?
 - Why is or isn't it reasonable?
 - If it isn't reasonable, explain what is wrong with the answer and rethink the problem.

6.3 Solve and Graph Inequalities, Interpret Inequality Solutions

Section Overview: Students begin this section by reviewing from 6th grade how to write inequalities and graph them on a number line. They then move to solving and graphing one-step and multi-step inequalities using their knowledge of solving one-step and multi-step equations. The section ends with students writing and solving one- and multi-step contextual inequality problems.

Throughout this section it is important that students understand the similarities and differences between finding the solution to an equation and finding solution(s) to an inequality. Students should also understand the relationship of each to the real line.

Language is particularly difficult for some students in this section. Phrases like “less than” or “greater than” in the previous section indicated an operation (e.g. subtract or add), in this section they may indicate $<$ or $>$. Help students to look at contexts holistically. Making sense of problem situations is critical with writing equations and/or expressions. Also help students predict the type of answers they will be getting as a way of interpreting how to write the context in algebraic form.

Students will also be reviewing number sense with integers in this section.

Concepts and Skills to be Mastered (from standards)

By the end of this section, students will be able to:

1. Use variables to create inequalities that model word problems.
2. Solve word problems leading to linear inequalities.
3. Use symbols of inequality to express situations in which solutions are greater than or less than a given value.

6.3a Class Activity and Homework: *Review of Inequality Statements.*

Review from 6th grade: writing and graphing inequalities.

Write inequalities for each statement below. For statements 1 – 4, the variable is identified for you. For statements 5 – 15, you must write what the variable will represent.

Example: The Garcia family car seats seven (with seat-belts) at most. " <i>x</i> " is the number of people that can sit in the Garcia's car.	$x \leq 7$
1. A school bus can seat at most 48 students. " <i>x</i> " is the number of people that can ride the bus.	
2. In many states you must be at least 16 years old to obtain a driver's license. " <i>x</i> " is the age you must be to obtain a drivers' license.	
3. It isn't safe to use a light bulb of more than 100 watts in many light fixtures. " <i>x</i> " is how many watts a light fixture has.	
4. At least 250 parents attended back-to-school night. " <i>x</i> " is the number of parents that attended back-to-school night.	
5. You must be no more than 15 years old to attend the middle school dance.	
6. A plane must travel at least 120 miles per hour to stay in the air. So as not to break the sound barrier, a plane must travel under 760 miles per hour.	
7. Children must by at least 48 inches tall to ride the roller coaster.	
8. You must have less than 3 tardies to get a satisfactory citizenship grade.	
9. Children younger than age 5 can get in free.	
10. To hunt big game in Utah a hunter must be at least 12 years old.	
11. The elevator can hold a maximum of 20 people	
12. To work the track at the community gym, you must be at least 16 years old.	
13. To join the FBI, you must be at least 23, but younger than 37 years old.	

14. To run the class they must have no less than 12 participants registered.	
15. On the seven day family vacation, the Jones family traveled 12 miles on the shortest driving day and 500 miles on the longest driving day.	

Write situations to go with the following inequalities. Make up the situation and inequality for the last one.

16.	$x < 7$
17.	$x \geq 13$
18.	$x \leq -6$

Review: graphing inequalities on a number line:

Examine the inequality graphs below. Discuss the questions below as a class.

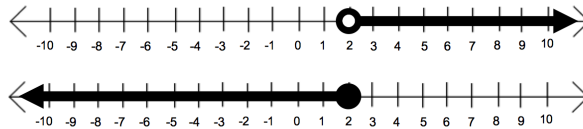

How are the inequalities shown on the number line?

Open circle means:

Closed circle means:

Next to each number line above, write the inequality represented by the number line above.

Practice Graphing Inequalities on a number line.

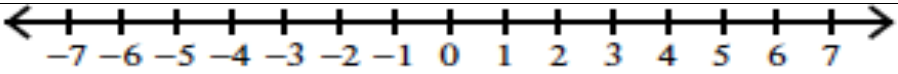
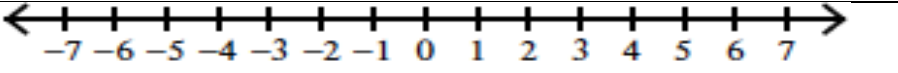
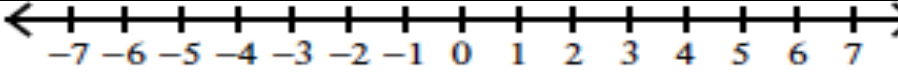
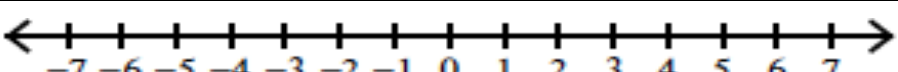
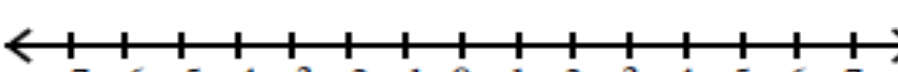
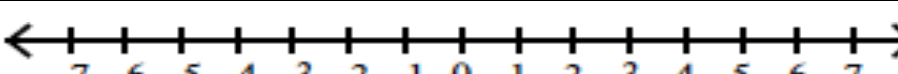
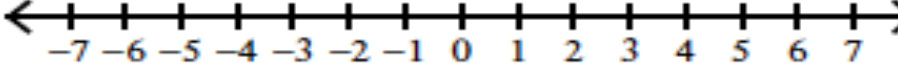
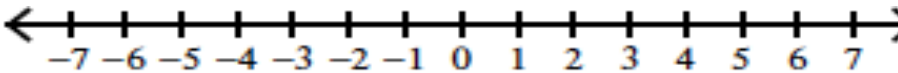
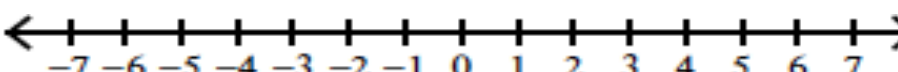
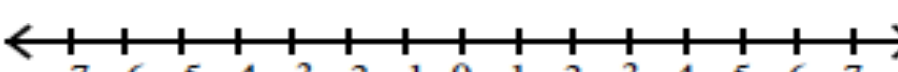
19. $x > 2$	
20. $a < -1$	
21. $y \leq 2$	
22. $b > -3$	
23. $p \geq 3$	
24. $x < .5$	
25. $y > -1\frac{1}{2}$	
26. $m \leq 3.5$	
27. $c \geq \frac{-15}{3}$	
28. $d \leq 4.25$	

Write an inequality for each graph below.

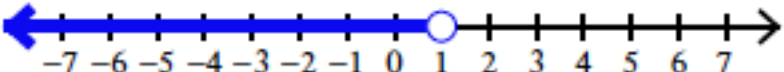
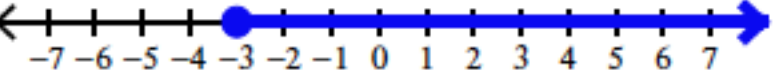
29.	
30	

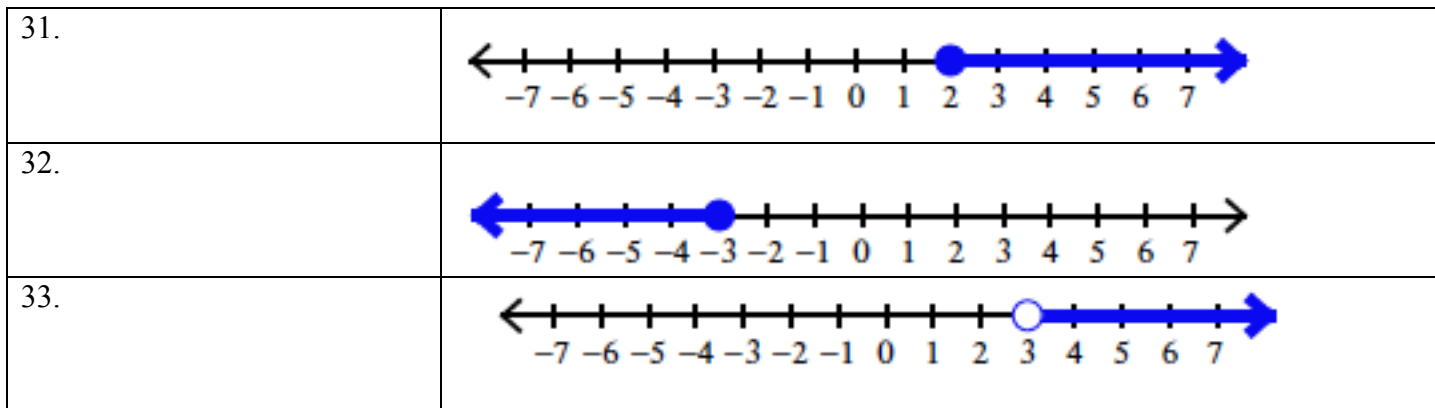

Spiral Review

1. There are a total of 127 cars and trucks on a lot. If there are four more than twice the number of trucks than cars, how many cars and trucks are on the lot?

2. Place the fractions on the number line below.

$$-\frac{3}{4}, \quad \frac{5}{12}, \quad -1\frac{1}{4}, \quad -\frac{4}{3}$$

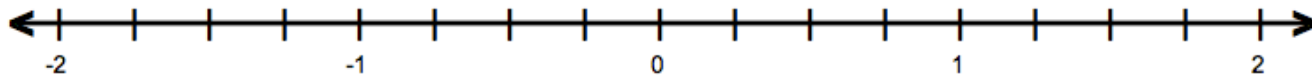

3. A mouse can travel 1.5 miles in $\frac{3}{4}$ of an hour. Write an equation showing how far it travels.
4. Solve $-3x + 5.5x + 4 = 7.2$
5. Fill in the equivalent fraction and percent for this decimal:

Fraction	Decimal	Percent
	0.2	

6.3b Class Activity: Solve and Graph Inequalities

Activity 1: Every hour 92 people enter an office building and 30 people exit. If the building starts empty, after how many hours will there be more than 350 people in the building.

- Draw a model to illustrate what's happening in this context.
- In this context, what does "more than"?
- Write an inequality for the situation.
- If you double the people entering and exiting, how will it affect your time?

Activity 2: A 150-pound person burns 6 calories per minute when walking at a speed of 3.5 miles per hour. While walking, this person eats a snack that has 40 calories. This snack subtracts from the calories burned while walking.

- How long must the person walk at this speed to burn at least 190 calories?
- Explain what will happen if the person walks for a longer period of time? Shorter period of time?
- Write and graph an inequality that describes the solution to this situation.
- Extension: What if the person wanted to spend less time exercising but burn the same number of calories. How is this possible?

Activity 3: Explore Inequality Statement: Consider the following two inequality statements

$$x \leq 2 \quad \text{and} \quad 2 \leq x$$

In your own words, describe the solution set for each and then draw a graph of the solution set.

Activity 4: Exploring Inequality Statements:





- a. What is the solution set for $x - 1 > 6$. In other words, what value(s) of “x” make this statement true? Write both an inequality statement and graph your solution on a number line.

- b. What is the solution set for $2x < 6$. In other words, what value(s) of “x” make this statement true? Write both an inequality statement and graph your solution on a number line.

- c. What is the solution set for $3x - 7 \geq 13$. In other words, what value(s) of “x” make this statement true? Write both an inequality statement and graph your solution on a number line.

- d. Describe what you did to find the solution set.

Find the solution set for each inequality. Then graph the solution set. Scale the number lines appropriately.

1. $x + 8 \geq 18$	
2. $-2 + x \leq -16$	
3. $-28 < v - 10\frac{1}{2}$	
4. $4y > -8$	
5. $21 \leq 3p$	

6. $-15 > 2x$



7. $4r + 13 < 9$



8. $\frac{r-2}{3} > \frac{1}{3}$



9. $11 \geq 8 + 6n$



10. $5n - 75 \geq -135$



11. $18.\overline{66} + 2k \leq 10$















12. $-4 \geq 4x + 16$



6.3b Homework: Solve and Graph Inequalities

Solve to find the boundary. Then graph the inequalities below. Scale the number lines appropriately.

1. $n - 2 \leq 4$	
2. $-18 + n < -7$	
3. $20 \geq p + 16.5$	
4. $2x < 6$	
5. $-24 \leq 3p$	
6. $3y > 17$	
7. $-4 \geq -2 + 6n$	
8. $3x - 1 \leq 3$	
9. $21n - 63 > -126$	
10. $9.5 + 2n > -5$	
11. $2x - 1 > 6$	
12. $\frac{3}{4} > \frac{-2 + 2x}{4}$	

Spiral Review

1. Solve $-3(x - 6) = 9$
2. Find each product or quotient.
 - a. $-6\left(\frac{1}{6}\right)$
 - b. $-10 \div \frac{1}{2}$
3. Suppose you were to roll a fair 6-sided number cube once, then flip a coin. List all the possible outcomes.
4. Using the information in question 3, what is the probability of getting a heads and an even number?
5. Dawn is researching car rental companies. The following tables show their rates based on the days you rent the car. Which company's rates are proportional? Explain how you know.

Company E	
Days	Cost
1	73
2	76
3	79
4	82

Company F	
Days	Cost
1	21
2	42
3	63
4	84

6.3c Class Activity: Multiplying by a negative when Solving Inequalities

Consider the inequality $4 > 1$.

- Question: If you multiply both sides of an inequality by the same *positive* number do you expect the inequality to remain true? Why or why not?
- Question: If you multiply both sides of an inequality by the same *negative* number do you expect the inequality to remain true? Why or why not?

1. Test your answers from above. Complete the table by filling in the middle column with $<$, $>$, or $=$.

4	$>$	1	True or untrue?	If untrue, what must be done for the inequality to be true?
$4 \bullet 3$	$>$	$1 \bullet 3$		
$4 \bullet 2$	$>$	$1 \bullet 2$		
$4 \bullet 1$	$>$	$1 \bullet 1$		
$4 \bullet 0$	$>$	$1 \bullet 0$		
$4 \bullet -1$	$>$	$1 \bullet -1$		
$4 \bullet -2$	$>$	$1 \bullet -2$		
$4 \bullet -3$	$>$	$1 \bullet -3$		

2. Under what conditions did the inequality become *untrue*? Why does that condition make the inequality untrue?

3. Solve the inequality $\frac{x}{-2} < 2$, explain your procedure. Write and graph the solution.



4. Check your solution for varying values for x . Is your graph correct?

In the inequality $\frac{x}{-2} < 2$, if the value for x is...	-8	-6	-3	-2	0	2	4	6	8
Write the inequality.									
...is your solution set true?									

5. Solve and graph the solution to $\frac{x}{-3} \geq -9$.

Check your values in your solution set to make sure your answer is correct.

6. What about dividing by a negative number? What do you expect? Solve and graph the inequality $-2x > 6$, explain your procedure.

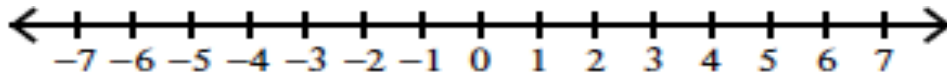

7. Test your solution.

In the inequality $-2x > 6$, if the value for x is...	-8	-6	-3	-2	-1	0	2	4	6
Write the inequality.									
...is your solution set true?									

8. Finish this sentence: When you multiply or divide both sides of an inequality by the same negative number...

Solve the following problems by first writing an inequality and then solving the inequality.

9. Kyle and Mika aren't very good at the trivia game. In the game a wrong answer gives your team a negative two-thirds of a point. If at the end of the game, Kyle and Mika have never scored more than a negative 8 points, how many wrong answers do they usually give?

Inequality:







Solution:

10. You have \$10 to spend at the school carnival. If each game costs \$0.25, how many games can you play?

Inequality:









Solution:





Practice solving inequalities involving multiplication or division by negative numbers.

11. $-5t \geq -25$	
12. $\frac{-2y}{3} < -4$	
13. $-\frac{1}{2}p > -4$	
14. $\frac{y-3}{-4} \leq 5$	
15. $-5 \geq -2 - 3n$	
16. $-18 \geq \frac{-x}{2}$	
17. $-2(x+4) \leq 28$	

6.3c Homework: Multiplying by a negative when Solving Inequalities

Solve the following inequalities. Graph your solution on the number line.

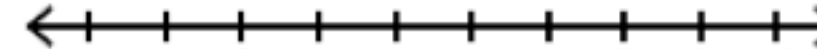
1. $-3t \geq 27$	
2. $\frac{-y}{3} < -10$	
3. $-\frac{3}{4}m > 6$	
4. $\frac{5n}{-2} > -1.5$	
5. $-28 \geq -4n - 4$	
6. $7.5 - 2n > -2$	
7. $-3(x - 4) \leq 24$	
8. $-\frac{3}{4}n - 21 > -15$	

<p>9. $-6.5 + 2n > -5$</p>	
<p>10. $2x - \frac{2}{3} > \frac{16}{3}$</p>	
<p>11. $0.75 > \frac{-2x}{4}$</p>	
<p>12. $\frac{x}{7} - \frac{2}{3} > \frac{13}{3}$</p>	

Spiral Review

1. Solve for a . $a + \frac{3}{4} = 5$

2. Factor the following expressions.

$3x - 6$

$15 - 20y$

$\frac{5}{3}x + \frac{2}{3}$

$4.9t - 2.8$

3. Bubba can make $7\frac{1}{2}$ sandwiches in $\frac{1}{2}$ hour. Find the following unit rates

a. _____ sandwiches per hour

b. _____ hours per sandwich

c. _____ minutes per sandwich

4. Solve: $-2x + 1 < -3$

5. Chloe has twice as many cats as her sister has dogs. Her brother has 3 turtles. Together, they have six pets. How many of each pet do they have?

6.3d Class Activity: Write and Solve Inequalities for Word Problems

Follow the structure below to solve and graph each inequality. The first problem has been started for you as an example.

- Andy has \$550 in a savings account at the beginning of the summer. He wants to have at least \$200 in the account by the end of the summer. He withdraws \$25 each week for food, clothes, and movie tickets. How many weeks will his money last?

Known Information <ul style="list-style-type: none"> Starts with \$550 Takes away \$25 each week Wants at least \$200 in the end 	Variable and what it represents w = number of weeks money can last	What's the relationship? The money Andy has needs to be more (bigger) than or equal to \$200	Inequality $550 - 25w \geq 200$
Solution and what it means			

- On vacation, Katelyn wanted to have her hair braided in multiple braids to cover her head. The beautician charges a flat rate of \$4, plus \$0.75 per braid. She's saved \$29 to get braids. How many braids can she get?

Known Information	Variable and what it represents	What's the relationship?	Inequality
Solution and what it means			

- Maria is starting a small DVD business online. She makes \$2.25 on each DVD she sells. To start her business though, she had to invest \$750. How many DVDs does she need to sell before he starts to make a profit?

Known Information	Variable and what it represents	What's the relationship?	Inequality
Solution and what it means			

4. The Community Swimming Pool charges a flat rate of \$50 for a birthday party plus \$2.50 for each person. Deborah can't spend more than \$100. How many friends can she invite?

Known Information	Variable and what it represents	What's the relationship?	Inequality
Solution and what it means			

5. David owns a Yellow Cab. The company charges a flat rate of \$2.50 for every cab ride, plus \$0.85 per mile. David figures he needs to average at least \$12 for each cab ride to make a profit. At least how many miles must rides average to make a profit?

Known Information	Variable and what it represents	Inequality Sign	Inequality
Solution and what it means			

6. Jacques has a pre-paid phone plan. He has \$45 to spend and each minute costs \$0.39, what is the most minutes he can buy?

Known Information	Variable and what it represents	Inequality Sign	Inequality
Solution and what it means			

7. Harry wants to download some songs to his mp3 player. If he gets a \$20 gift card for his birthday and each song costs \$0.90, at most how many songs can he download?

Known Information	Variable and what it represents	Inequality Sign	Inequality
Solution and what it means			

6.3d Homework: Write and Solve Inequalities for Word Problems

Write and solve inequalities for each word problem below. Use the structure from Class Activity 6.3d as a frame for solving each.

<p>1. Kimberly took her 6 nieces and nephews to a hockey game. She wants to buy them snacks. How much can she spend on snacks for each child if Kimberly wants to spend less than \$33 in total?</p>	<p>2. The school is having a fundraiser. They are running a carnival. Tickets sell for \$0.50 each. They are planning on buying supplies for the carnival that cost \$50. How many tickets must they sell to raise at least \$200?</p>
<p>3. Billy needs to read 500 minutes this week for his English class. He is going to read 6 days. If he already reads 15 minutes every day, how many additional minutes does he need each day to read at least 500 minutes?</p>	<p>4. Erin is buying cupcakes for her birthday party. Each cupcake costs \$1.50. How many guests can she invite if her budget is \$80 and she has already spent \$16 on paper cups and plates? By the way, Erin thinks that each guest will want two cupcakes to eat.</p>
<p>5. Lauren got \$321 from various relatives on her birthday. If she wants to put 20% of the money into her savings account, how much will she have left over to spend on new clothes?</p>	<p>6. Peter is trying to set a new record for pizza deliveries. His previous record is 20 pizzas in one hour. He has already delivered 2 pizzas in 5 minutes. How many pizzas will he need to average per minute to beat his previous record?</p>

<p>7. Mrs. Brown is ordering pictures of her new baby. There is a \$20 sitting fee and each 5x7 portrait she orders is \$4. She also has a coupon for \$10 off. If she wants to spend less than \$50, how many 5x7 portraits can she order?</p>	<p>8. Stuart's Painting Service charges a \$50 supplies fee plus \$10 per hour painting. Andrew's Awesome Painting charges a \$20 supplies fee plus \$20 per hour painting. For how many hours does Andrew charge less than Stuart?</p>
<p>9. The technology department is having a fundraiser. They want to make at least \$1000 by selling hoodies for \$25. Each hoodie costs them \$15. How many will they need to sell to reach their goal?</p>	

Spiral Review

1. Solve the following inequality: $25 > 2x + 8 - 66$









2. Lara has \$1,425 in her bank account. Write and solve an equation to show how much money she started with if that amount reflects a 14% increase on her original amount.



3. There are 36 red and 44 blue marbles in a bag. What is the probability of randomly drawing a red marble?

4. Jordyn runs $2\frac{1}{2}$ kilometers in $\frac{1}{3}$ hours. If she continues running at the same pace, how long will it take her to run 40 kilometers? (Hint: First, find the unit rate.)







5. Solve the following equation. Use a model if needed. $2(m - 1) + 3m - 4 + m = 18$



6.3e Class Activity: Solve Inequalities Review

1. $-13m + 46 > -45$	
2. $-6h - 16 < -34$	
3. $11a - 19 \geq 9a + 5$	
4. $12y + 8 > 56$	
5. $\frac{x}{7} - 20 \geq -12$	
6. $25 \leq -\frac{5}{6}d$	
7. $-12 - 14n < 20 - 6n$	
8. $-16 \geq -5(y + 0.2)$	

<p>9. $-\frac{1}{2}x - 1 > 6$</p>	
<p>10. $\frac{-3x+1}{2} \leq 8$</p>	
<p>11. Aimee wants to order some DVDs from Amazon. Each DVD costs \$8.49 and shipping for the entire order is \$5. She has only \$70 to spend. How many DVDs can she order?</p>	
<p>12. On vacation, Jocelyn wants to have her hair braided in multiple braids to cover her head. It costs a flat rate of \$3, plus \$0.85 per braid. She had saved \$32. How many braids can she get?</p>	
<p>13. The Community Swimming Pool charges a flat rate of \$60 for a birthday party plus \$2.25 for each person. Juan can't spend more than \$120. How many friends can he invite?</p>	

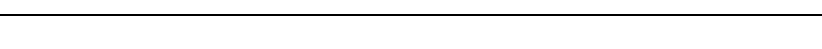
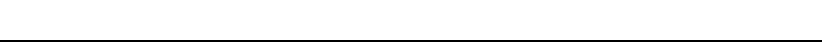
6.3e Homework: Solve Inequalities Review

1. $8e \geq -64$	
2. $d + (-13) \leq 26$	
3. $3 > \frac{-2+2x}{-2}$	
4. $-\frac{4}{3}(y-3) \leq \frac{3}{4}$	
5. $-9(m-6) > 99$	
6. $\frac{-x}{5} - \frac{3}{5} > 4.4$	
7. $15 - 3y + 8y > 7$	
8. $-\frac{2}{5}(6+x) < 2$	

9. $28 \leq 9 + 7y + 5$	
10. $-23 \geq -4(y - 0.25)$	
11. Van has an old cell phone he has to buy minutes for. He has \$55 to spend and each minute costs \$0.49, what is the most minutes he can buy?	
12. The Yellow Cab Taxi charges a flat rate of \$3.50 for every cab ride, plus \$0.95 per mile. Tofi needs a ride from the airport. He only has \$30 cash. How many miles can he go?	
13. Vicki wants to play a video game that charges you \$0.12 per minute. If she has \$15 to spend, how many minutes can she play at most?	

Spiral Review

1. A spinner contains three letters of the alphabet.

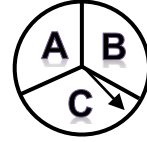

- How many outcomes are possible if the spinner is spun three times?
- List all of the outcomes for spinning three times.
- What is the probability of getting exactly one A in three spins?

2. Express each percent as a fraction in simplest form.

35%

22%

3. Simplify the following expression. Use a model if needed. $71b - 4a + 4b - 4a$

4. What is 30% of 150? Use a bar model.

5. Will the following side lengths make a triangle? Why or why not?

- 5 cm, 4 cm, 18 cm
- 3 ft, 3 ft, 2 ft
- 3 in, 6 in, 3 in

6.3f Self-Assessment: Section 6.3

Consider the following skills/concepts. Rate your comfort level with each skill/concept by checking the box that best describes your progress in mastering each skill/concept. Sample problems can be found on the following page.

Skill/Concept	Beginning Understanding	Developing Skill and Understanding	Practical Skill and Understanding	Deep Understanding, Skill Mastery
1. Solve a linear inequality and check your solution.	I can solve one and two-step inequalities with whole numbers, but I struggle to solve multi-step equations or ones with rational numbers.	I can solve multi-step inequalities involving calculations with whole numbers.	I can solve multi-step equations involving calculations with integers. I can also check my solution.	I can solve multi-step inequalities involving calculations with rational numbers. I can also check my solution.
2. Create an inequality with variables that models a context.	I struggle to begin writing an inequality that models a context.	I can draw a model that represents a context. I struggle to use that model to create an inequality.	I can write an inequality that represents a context if I draw a model first.	I can write an inequality that models a context.
3. Solve word problems leading to linear inequalities.	I struggle to solve word problems leading to linear inequalities.	I can usually write an inequality to solve a word problem leading to a linear inequality, but I struggle using that inequality to get a solution.	I can solve word problems leading to linear inequalities.	I can solve word problems leading to linear inequalities. I can explain the solution in context.
4. Determine the reasonableness of a solution to a contextual inequality.	I struggle to determine the reasonableness of an answer to a contextual inequality.	I can determine if the answer to a contextual inequality is reasonable, but I struggle to explain why.	I can determine if the answer to a contextual inequality is reasonable, and I can to explain why.	I can determine if the answer to a contextual inequality is reasonable, and I can to explain why. If it is not reasonable, I can rethink that problem to find a reasonable answer.

Sample Problems for Section 6.3

1. Solve each of the following equations with or without a model.

a.

$-1 < x + 7$	$2x + 3 > 7$	$30 \leq \frac{x}{7} - 20$
--------------	--------------	----------------------------

b.

$3(x - 6) \geq 9$	$3 \leq \frac{2x + 4}{2}$	$3x + 5x + 4 > 4$
-------------------	---------------------------	-------------------

c.

$-2(x - 9) \geq -7$	$4 \leq \frac{-6x + 6}{6}$	$-2x + 8x + 4 > -8$
---------------------	----------------------------	---------------------

d.

$0.8x + (-8) < 0$	$\frac{1}{2}(-2x - 7) > \frac{3}{4}$	$-\frac{1}{4} \leq 2.4x + 10 - 3.5x$
-------------------	--------------------------------------	--------------------------------------

2. Write an inequality for each context. Draw a model first if necessary.
- A moving company is shipping my stuff on a move from Sandy to St George. The maximum weight on Utah roads for a truck is 80,000 lbs. If the empty truck and trailer weigh 32,500 lbs and other people have stuff on the truck already weighing 35,000 lbs total, how much can my stuff weigh?
 - In Whatsitville, speeding tickets are fined \$75 plus \$13 for every mile over the speed limit. If Mr. Bo is pulled over and told his ticket will be at least \$400. At least how much over the speed limit was he?
 - Jenna's credit card requires that she pay at least 10% of her balance each month. If she pays at least \$44, what is the most her balance could be?
3. Write an inequality to represent each of the following word problems. Solve each problem. Explain your solution in context.
- Loralie is having a birthday. She wants to bring treats for her friends at school. Her mom gives her \$20. How much can she spend per friend if she wants to bring treats for herself and eight friends?
 - Jeremy is two years older than Rachel. The sum of the ages of Jeremy and Rachel is less than 46. How old could Jeremy be?
 - Kathryn is five years old and so excited to ride all the rides at the local amusement park. Unfortunately, she is 42.5 in tall and one ride requires that she be at least 50 in. You want to tell her in about how many years, she'll be able to ride. A quick google search shows that the average child grows $2\frac{1}{2}$ in per year. How many years will you tell Kathryn it will be until she can ride all the rides?
4. For each of the contexts in problem 3, answer the following questions:
- Is the answer reasonable or not?
 - Why is or isn't it reasonable?
 - If it isn't reasonable, explain what is wrong with the answer and rethink the problem.